

BLAIR COMPANIES



LED ELECTRONIC PRICE CHANGE UNIT (EPCU) INSTALLATION INSTRUCTIONS

**REVISION 18E
8/21/2012**



BLAIR COMPANIES
ARCHITECTURAL IMAGING
SIGNS • FIXTURES • LOGISTICS

5107 Kissell Avenue
Altoona PA 16601
814-949-8287
blaircompanies.com

Visit www.blaircompanies.com/ledsupport to download these instructions

IMPORTANT WARRANTY INFORMATION PLEASE READ!

Warranty coverage will not begin until the installer completes the warranty card and installation checklist and submits that along with the completion photographs to Blair Companies. Please send these items within 30 days of installation to:

Blair Companies
5107 Kissell Avenue
Altoona, PA 16601
(814) 949-8287

Or email: LEDWarranty@blaircompanies.com

If a failure of the sign occurs before the warranty and installation checklist are submitted, the costs associated with the repair of the sign are the responsibility of the installer or the sign owner.

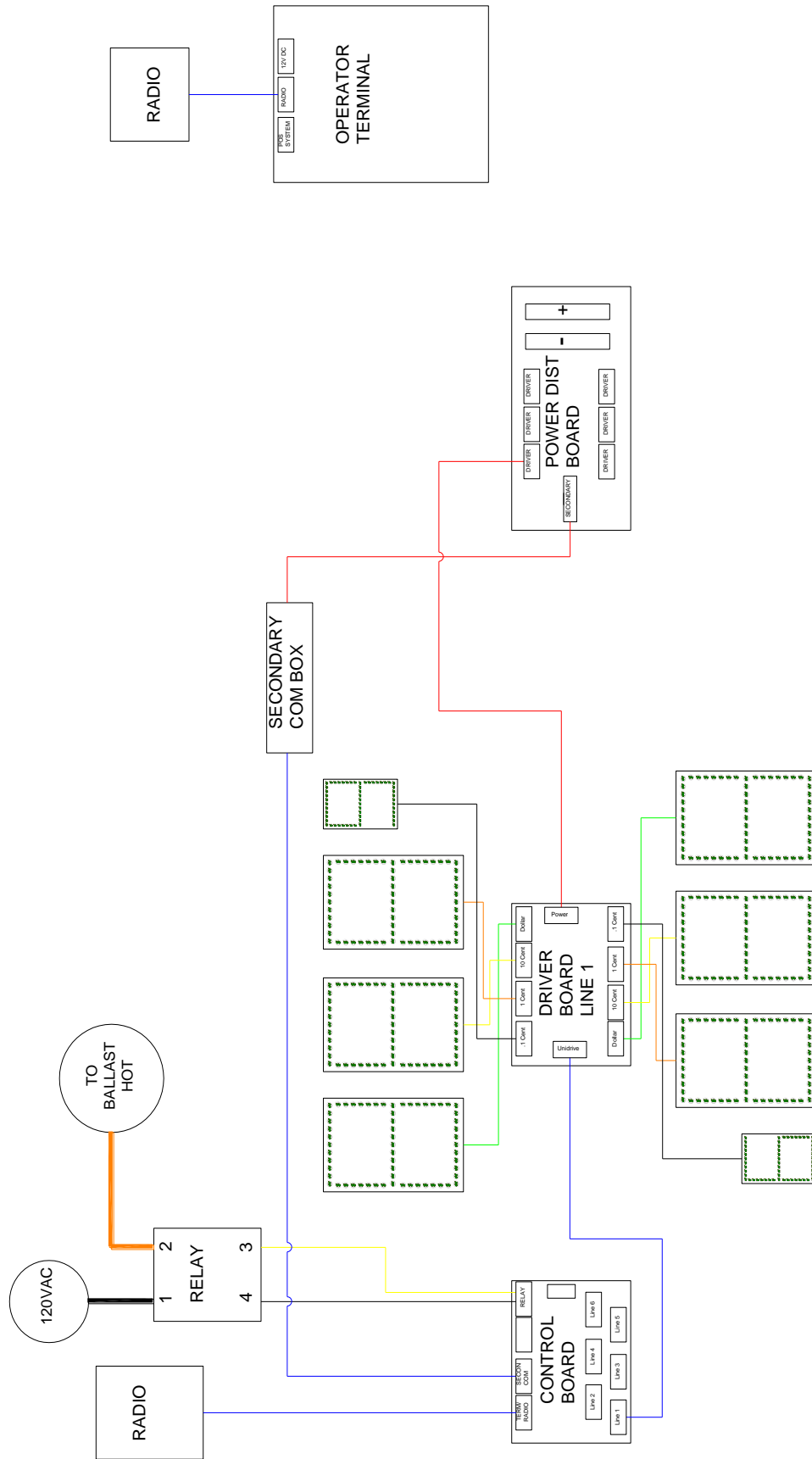
For more information regarding warranty, see page 10

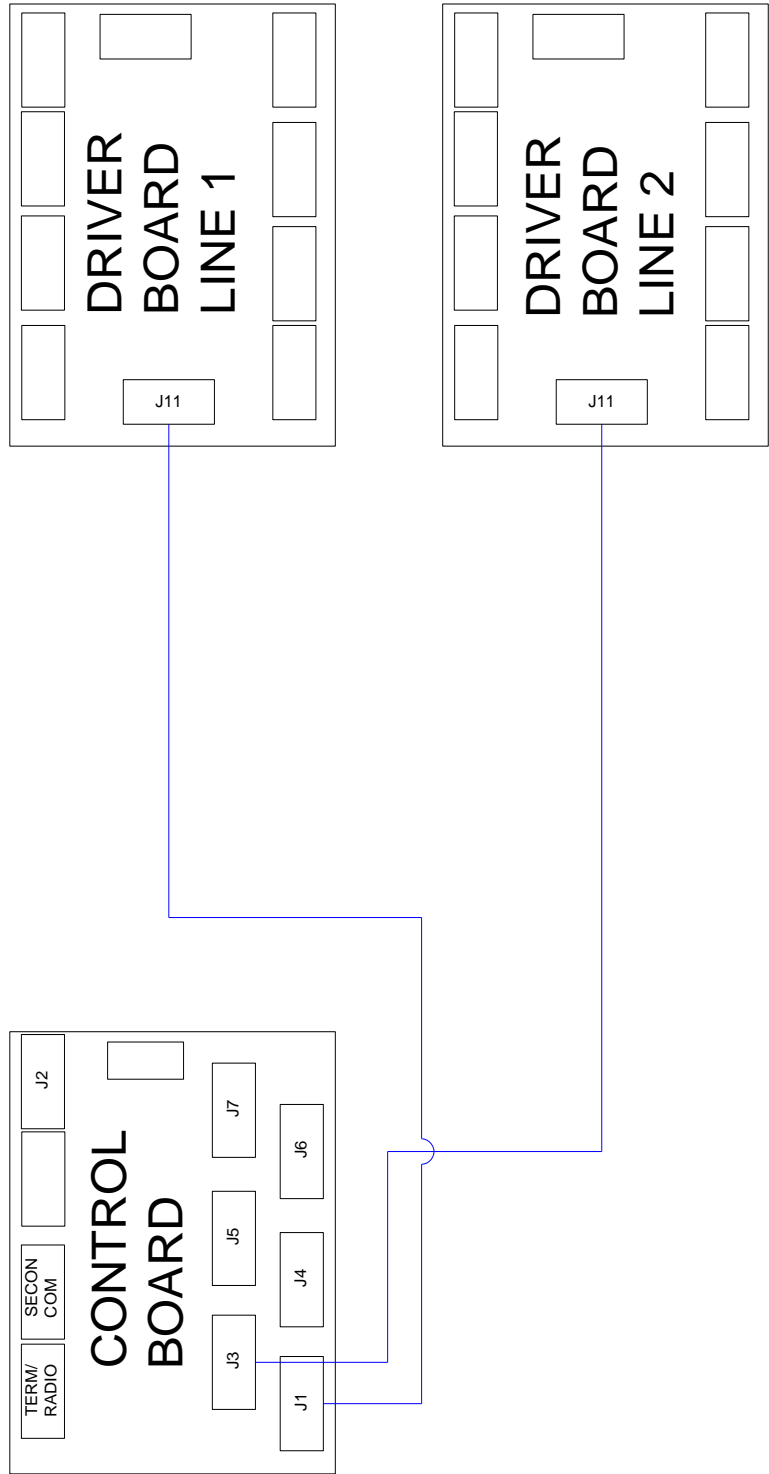


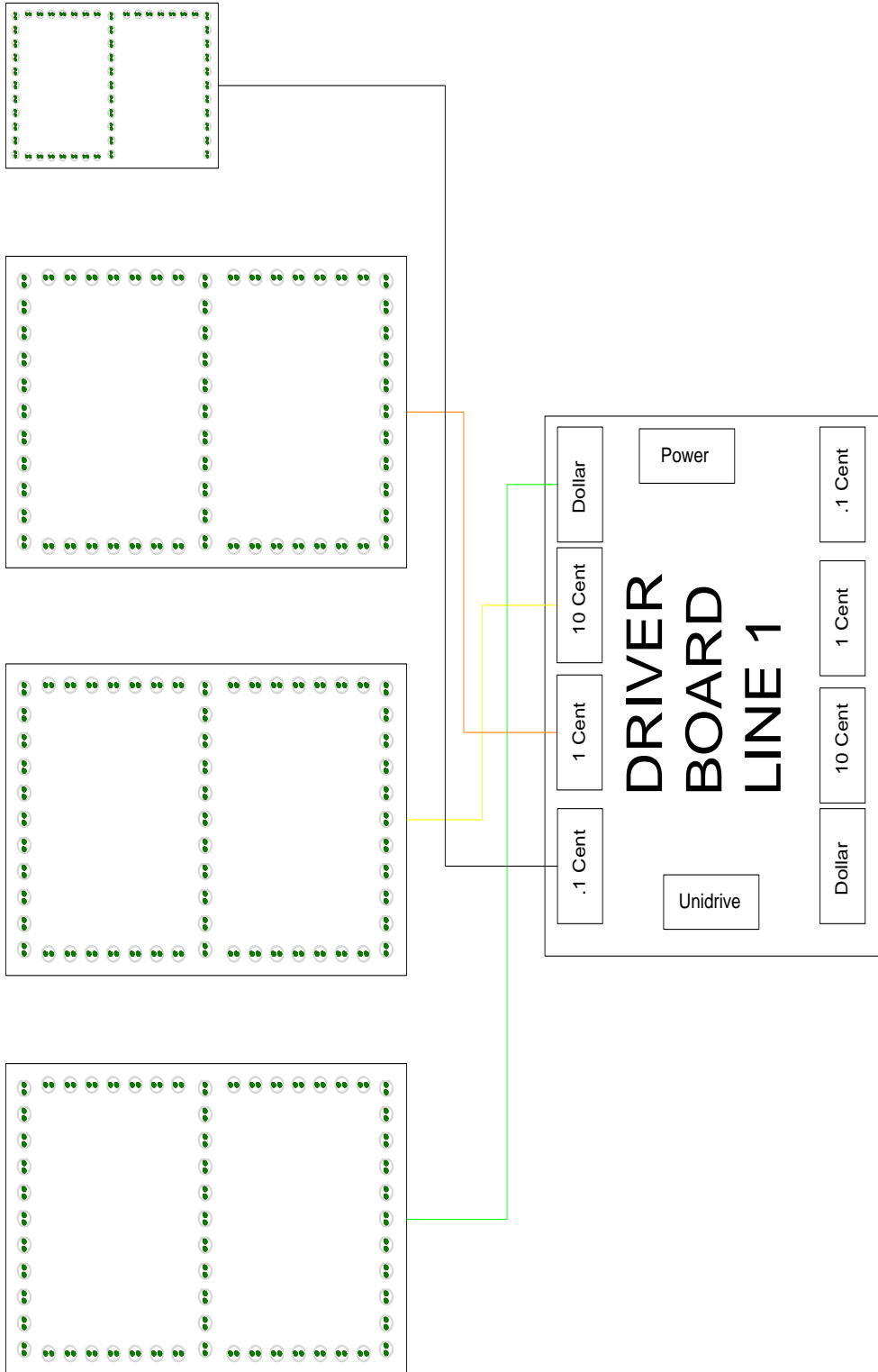
Table of Contents

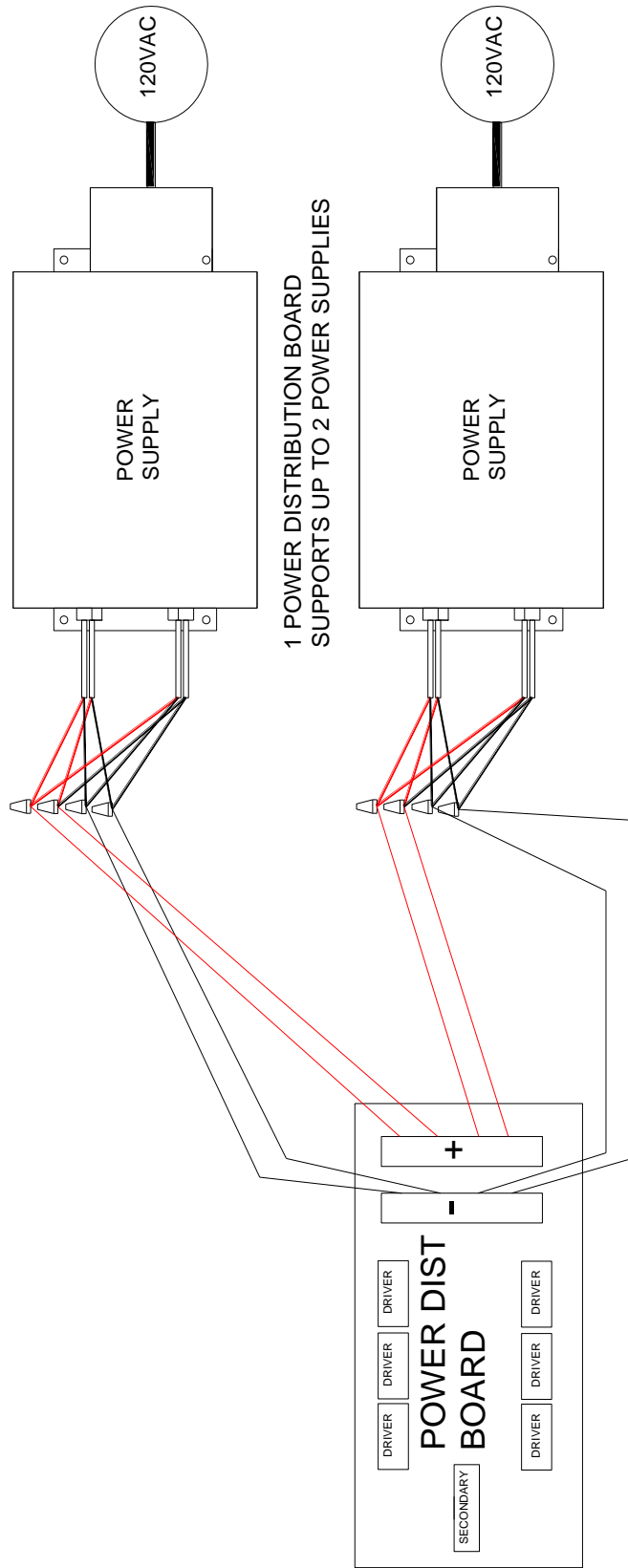
A. Schematics	4
B. Revision History	10
C. Warranty Information	10
D. Cautions and Warnings	11
E. Parts List	11
F. Determining Retrofit Requirements	13
G. Installing System	14
H. Control Board Service	19
I. Communication Methods	21
J. Radio Installation	23
K. Programming the Terminal	25
L. Programming EMC Mini.....	27
M. Programming with Economy Operator Terminal	28
N. Troubleshooting	30
O. BlairCompanies.com Logo Standards	33
P. Completion Photo Guidelines.....	34
Q. REQUIRED WARRANTY & INSTALLATION CHECKLIST.....	35
R. Contacts	36

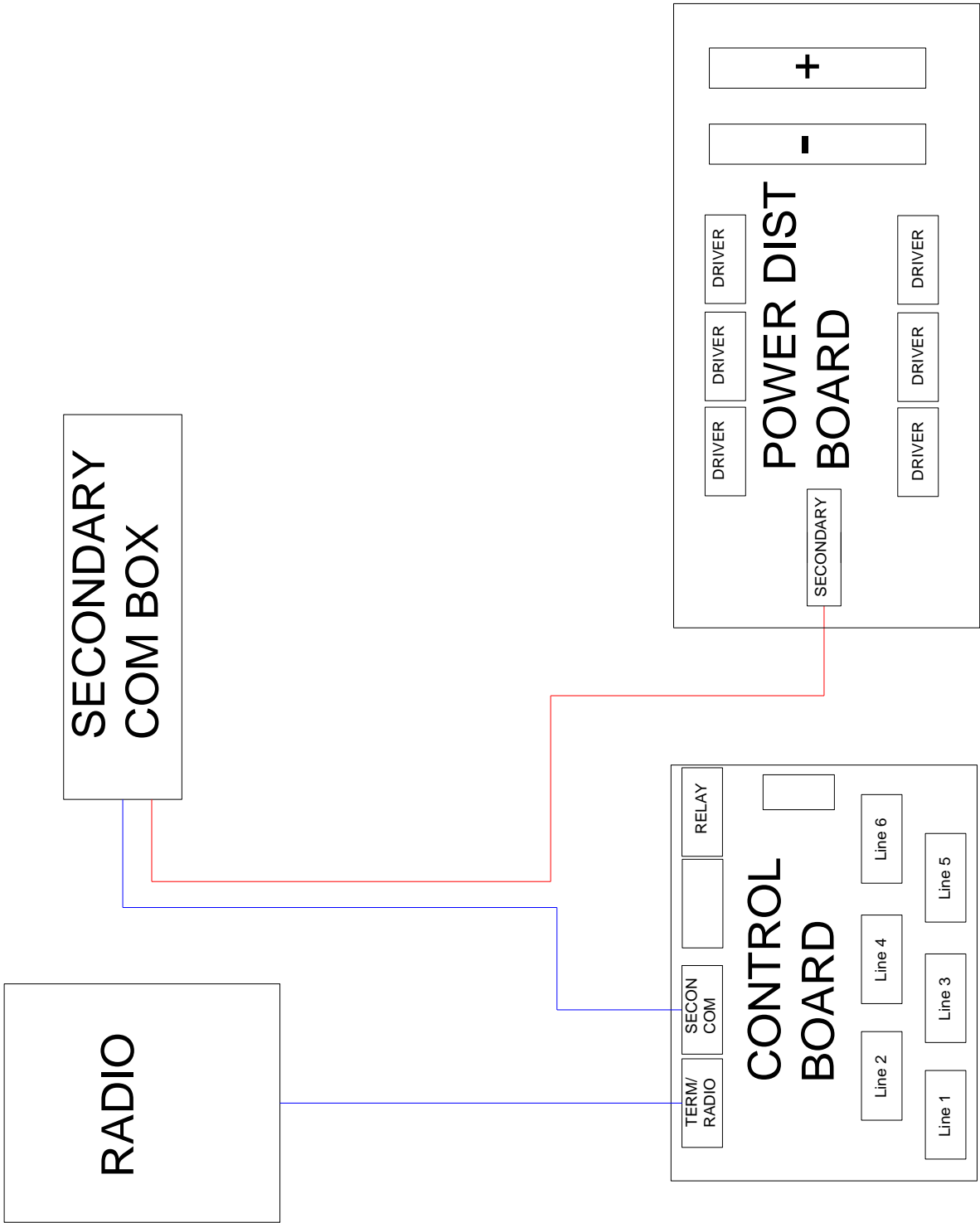
A. Schematics

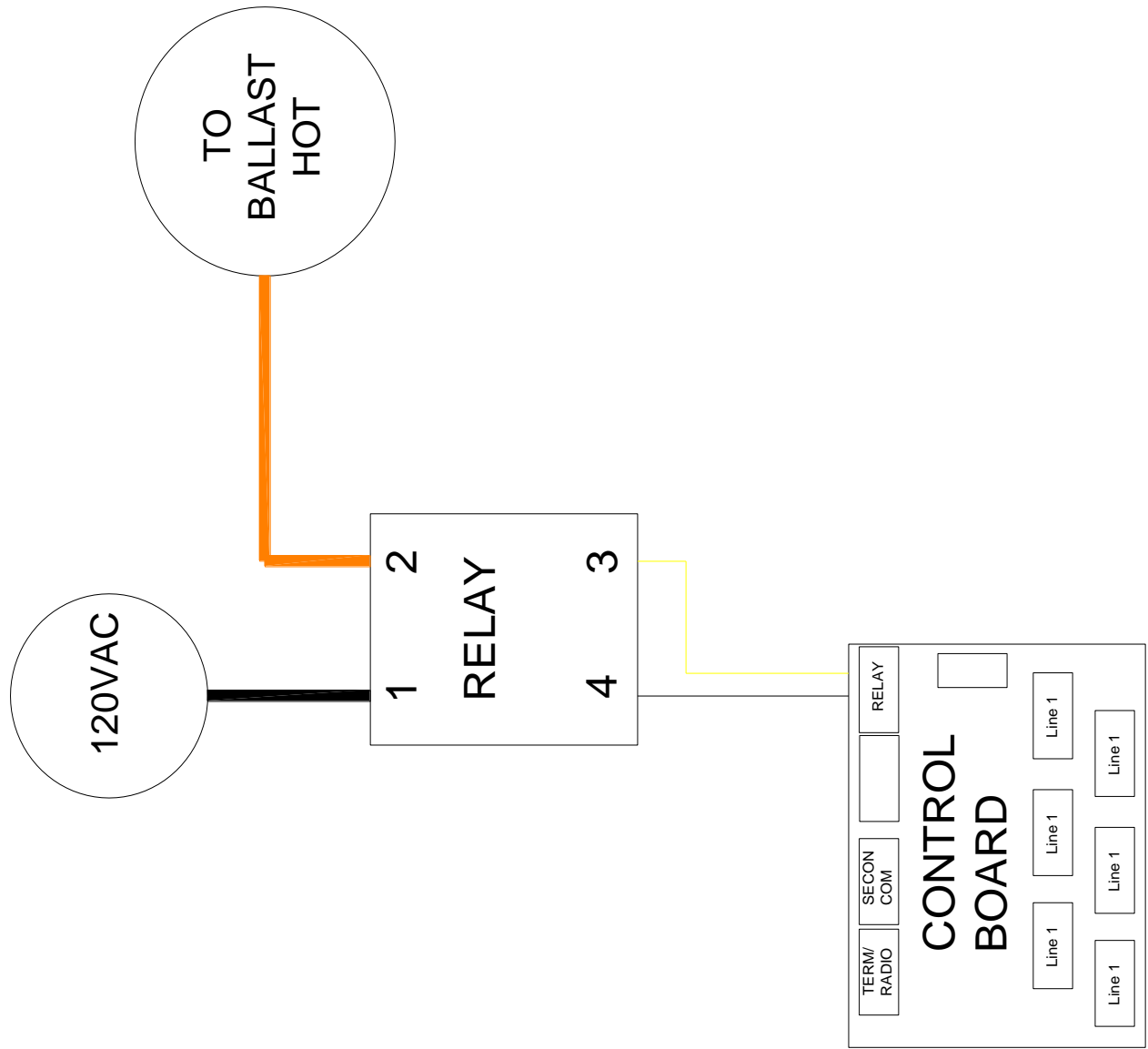












B. Revision History

R18E 8/21/12 *Made changes to verbiage of communication guidelines, wiring diagrams, installation practices*

R18D 11/19/10 *Height of mounting secondary box (G); Radio mounting verbiage cleanup (J); removed drip loop requirement;*

R18C 5/19/10 *Relocated schematic to start of manual; Contact info to end of manual; Power req't for all digit sizes; Single tab Standard Radio*

R18B 2/1/10 *Updated wording for lamping on circuit with EPCU, T8 availability, and control box mounting (C); Long Range Radios for controlling multiple signs per site (H); Power distribution board to parts list (D); Updated Logo Standards (P); Updated Control Box decal schematic (O); Combined Warranty Card and Checklist (R); Added Warranty Card to Operation Instructions; Operation Instruction decal on back of Operator Terminal; Restructured sections for System Wiring, Retrofit Requirements, Installing System, and Servicing Control Box to better reflect order of install steps; Knockout for digit cable replacement (F); Radio connect fitting (F); Potted Standard Radio; Modular Digits; 12V connection for Operator Terminal (I,J)*

R18A 12/2/09 *Dedicated Warranty section (B); Added Revision History (A); Silicone/Caulking statements (E,H); Troubleshooting diagram (P); Digit Cable Replacement access hole (H); Separate Installation Manual and Operator Manual; Expanded Radio Installation section (J); Completion Photo section (T); Updated part numbers (D)*

C. Warranty Information

Note: This system converts a fluorescent gas price sign to an LED gas price sign. It is designed to be installed into a UL-48 listed sign only. The UL Listing Mark must be on the sign being retrofitted. Any other use is strictly prohibited.

You must read and understand the instructions listed in this manual PRIOR to beginning installation.

Warranty Terms: The warranty covers normal use and service. Damage caused by vandalism, lightning strikes, electrical surges, and any other acts of God, and any consequential or contingent liability is excluded from this warranty. Warranty claims must be registered with Blair Companies within thirty (30) days of damage or malfunction. Blair reserves the right to visit the site of the installation or to require documentation of the claim before assuming any responsibility under the provisions of the warranty. Installer should check all materials within 24 hours after receiving them for shipping damage, missing parts, etc.

It is the installer's responsibility to provide grounding for the sign.























Installer must submit Warranty and Installation Checklist (Section S), and Completion Photos per photo instructions (Section R).

D. Cautions and Warnings

1. LED signs are not to be stored outside before installation. Depending on the orientation of the sign, water could enter the control box, causing damage to the electrical components.
2. LED signs are to be on (1) dedicated 120V AC, 20-amp circuit. Grounding the sign is the responsibility of the installer, and it is required to qualify for our warranty. See Section F for details.
3. **DO NOT** put any lights or electrical devices other than sign fluorescents (to turn on/off with system timer) on the same circuit with the LED sign. NOTE: If enough amperage capacity is not available, a lower energy T8 fluorescent retrofit may be available; contact your Blair representative to find out more.
4. It is the installer's responsibility to ensure the sign is weather proof upon completion of the installation. This includes installing any lids and covers.
5. Never run the LED portion of the sign off of a generator from a service truck.
6. Always disconnect power from the sign before service. Note: The power supply for the LED's will remain powered for a minute after power has been disconnected.
7. The control box must be mounted properly inside of the sign to ensure proper operation and reliability. The control box should hang from a support inside the sign so that the wires will not get damaged. Finally, do not modify the control box to make it fit into a sign. If it does not fit, you must order a custom box that will.
8. Low voltage wiring and communication cables need to be routed and secured away from any unenclosed line voltage wiring.
9. Always wear proper Personal Protective Equipment (PPE) when on-site. This includes any harnesses, gloves, safety glasses, vests, hard-hats, etc. Make sure to properly barricade entire work area with at least 4' tall orange fencing prior to starting any work.

E. Parts List

LED DIGIT PART NUMBERS	GREEN	RED	AMBER	BLUE	WHITE
6"	33-13-00	33-14-00	33-11-98	33-11-96	33-11-95
3" 9	33-13-03	33-14-04	33-14-26	33-14-30	33-14-40
6" 9/10	33-13-02	33-14-03	33-14-20	33-14-31	33-14-41
6" 9	33-13-01	33-14-01	33-14-27	33-14-32	33-14-42
9"	33-00-05	33-11-01	33-11-99	33-12-06	33-11-09
9" 9/10	33-13-04	33-14-05	33-14-21	33-14-33	33-14-43
12"	33-00-09	33-11-11	33-12-01	33-12-05	33-11-07
12" 9/10	33-13-05	33-14-06	33-14-22	33-14-34	33-14-44
12" 9	33-00-30	33-00-31	33-00-32	33-00-33	33-00-34
15"	33-00-15	33-11-05	33-14-28	33-14-35	33-14-45
15" 9/10	33-13-08	33-14-09	33-14-23	33-14-36	33-14-46
18"	33-00-10	33-11-12	33-12-02	33-12-07	33-11-10
18" 9/10	33-13-06	33-14-07	33-14-24	33-14-37	33-14-47
24"	33-00-11	33-11-13	33-12-03	33-12-08	33-11-08
24" 9/10	33-13-07	33-14-08	33-14-25	33-14-38	33-14-48
DECIMAL 12 LED	33-13-65	33-13-61	33-13-63	33-13-67	33-13-69
DECIMAL 4 LED	33-13-64	33-13-60	33-13-62	33-13-66	33-13-68
30" TOP	33-12-14	33-00-13	33-11-14	33-11-16	33-12-16
30" BOTTOM	33-12-15	33-00-14	33-11-15	33-11-17	33-12-17

 <p>Fully Controllable Driver 32-01-62</p>	 <p>24", 18", 15", 12", 9" Digit Cable 32-03-02</p>	 <p>Nc Secondary Cable 32-10-15</p>	 <p>Operator Terminal 33-31-00</p>
 <p>Standard Radio 33-33-12</p>	 <p>Terminal Power Supply 32-02-49</p>	 <p>Power Supply 32-01-01</p>	 <p>Power Supply 32-01-01</p>
 <p>6-32 Nutsert 33-05-01</p>	 <p>6-32 Screw 32-05-00</p>	 <p>Controller Board 32-06-30</p>	 <p>Driver Board 32-01-60</p>
 <p>Relay 32-00-50</p>	 <p>Long Range Radio Outdoor 33-33-00</p>	 <p>Msr-Nc (Cable Only) 32-03-09</p>	 <p>Long Range Radio Indoor 33-33-01</p>
 <p>Ps Unidrive Cable 1' 32-19-34 2' 32-19-35</p>	 <p>Nc Unidrive Cable 32-10-15</p>	 <p>Economy Operator Terminal Receiver 33-06-42</p>	 <p>Economy Operator Terminal Transmitter 33-06-43</p>
<p>Economy Operator Terminal Complete Kit (Includes Transmitter, Receiver, Firmware Updated Control Board) 33-06-44</p>	 <p>Power Distribution Board 32-19-21</p>	 <p>Modular Driver 32-08-09</p>	<p>Communication Adapters: Radio: Secondary Sign Base: Secondary Control Box: POS:</p>

F. Determining Retrofit Requirements

Power requirements for EPCU components with standard "9 only" (If "9/10" is desired, call Blair):

Single 30" face	80 Watts		
Single 24" face	63 Watts	Controller	2 Watts
Single 18" face	47 Watts	Terminal	2 Watts
Single 15" face	41 Watts	Standard Radio	1 Watt
Single 12" face	29 Watts	Long Range Radio	5 Watts
Single 9" face	23 Watts		

1. Determine the number of branch circuits supplying the sign. Also, determine the voltage and current rating of each branch circuit.
2. The voltage rating of the LED retrofit kit is 90-264VAC. The frequency rating is 47-63Hz.
3. Determine the total power consumption of the LED system using the chart above.

Add up the power ratings of the LED faces you'll be installing, plus the power ratings for the controller, terminal, and radio. Note that there are two different radios; use the one appropriate for your installation. If in doubt, use the long-range radio number.

Example: A double-faced sign with "Regular" 24 inch and "Diesel" 12-inch LED digits – One pair of 24 inch, one pair of 12 inch, a controller, a terminal, and a long-range radio
 $126+58+2+2+5 = 193$ Watts

4. Divide the total power obtained in Step 4 by 240, and round up to the nearest whole number. In this example, $193/240 = 0.804$, so it would round up to 1. Our power supplies have a power rating of 240 Watts, so this will determine the number of power supplies your sign will need. In our example, we would need only one power supply.
5. Power supplies use 3 amps of current from the electrical supply. Multiply the number of power supplies calculated in Step 4 by 3 to calculate amperage. In this example, $1 \text{ multiplied by } 3 = 3$.
6. Look at the existing sign nameplate to find its voltage and current ratings. Then, add the LED system current calculated in Step 5 to the current rating on the nameplate of the sign. This will be the signs' new current usage.
7. Determine the amp rating of the existing sign's electrical circuit. If the new current usage calculated in Step 4 is $> 80\%$ of the rated amperage of the existing circuit, more power will be required. If the existing circuit's rating is 15 amps, it could be replaced with a 20-amp circuit. If the existing circuit is already rated at 20 amps, an additional circuit will need to be run to power the LED system. **Caution: If more than one circuit is used to power the sign, all sign branch circuit breakers must be disconnected before service.** Consult NEC Article 600 for details.
8. If direct wire is going to be used instead of radio, please specify this when ordering.

If the existing sign has scrolls or any other mechanical price changing mechanism, it will need to be removed prior to installation of the retrofit kit. Use KO plugs to seal any unused openings left when conduit is disconnected from electrical enclosures or raceways.

The control box will be mounted to a support member directly behind the LED digits, between the fluorescent lamps. This will prevent the control box from causing shadows on the sign face. If supports are not in the correct location, additional aluminum brackets may need to be fabricated.

There are two methods of performing a retrofit:

1. Measure the visual opening and cabinet dimensions of the existing sign, and have a new face made with the LED digits mounted in it.
2. Mount the LED digits to the existing sign face (The best candidates for this are signs with polycarbonate faces, although the LED digits can be mounted to most sign faces). See Section G for mounting instructions.

To be able to make a face for your sign, we need to know the cabinet size, and the visual opening size. A detailed drawing of your sign will be needed as well. This will help determine a good mounting location for the control box.

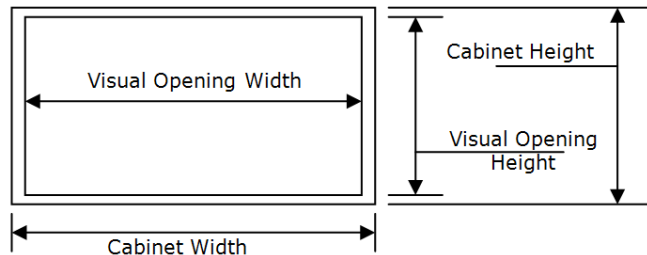

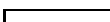








Figure 1: Dimensions required to make a new sign face

For digit sizes larger than 30", Blair offers a modular digit capable of being assembled into a variety of character heights. Contact your Blair representative to help assist in determining specifications for these custom sizes.

NOTE: Installer to verify existing face, retainer, and hinge structural integrity to support the added weight of LED retrofit tiles.

G. Installing System

	= 120VAC LINE (HOT)
	= 120VAC NEUTRAL
	= 120VAC GROUND
	= 120VAC SWITCHED LINE (HOT) TO FLUORESCENT BALLASTS
	= CONTROL CABLE FROM CONTROLLER BOARD TO DRIVER(S)
	= CONTROL CABLE FROM DRIVER BOARD(S) TO LED DIGITS
	= CONTROL CABLE FROM CONTROLLER TO FLUORESCENT RELAY
	= POWER CABLE FROM POWER SUPPLY TO DRIVER BOARD(S)

All line voltage wiring to the controller, power supply, and routing switch power for the ballast(s) needs to be in Listed 1/2in. Trade Size Flexible Metal Conduit secured by Listed conduit fittings. If flexible conduit is used, it must be secured correctly. It must be securely fastened every three feet or less, AND it must also be fastened within 12 inches of the control box and within 12 inches of the raceway. Consult NEC Article 356 for details.

The black, white, and green wires from the control box must be connected to a dedicated 120V 20-amp circuit.

Minimum electrical grounding consists of a dedicated 1/2" x 8' size copper grounding rod for the sign, and a #8 gauge copper grounding electrode which shall be terminated to the ground wire of the supply line. If the sign is surrounded by concrete, the grounding wire must be run back to the store, and terminated there. For Canopy Signs, the grounding wire can terminate to any structural steel member of the canopy. All signs must have the supply ground wire also connected to the steel frame of the sign. Do not use an Aluminum grounding electrode. In order to prevent any tripping hazards, please locate the grounding rod as close to the sign as possible, and bury the wire leading to the grounding rod at least 1-2 inches under the soil. Remember to Call 811"Call before you dig"

****A disconnect switch will be provided for Canadian installations.****

Conduit should be run behind or between the fluorescent lamps to avoid causing shadows on the sign face. See Figure 2 for an overview.

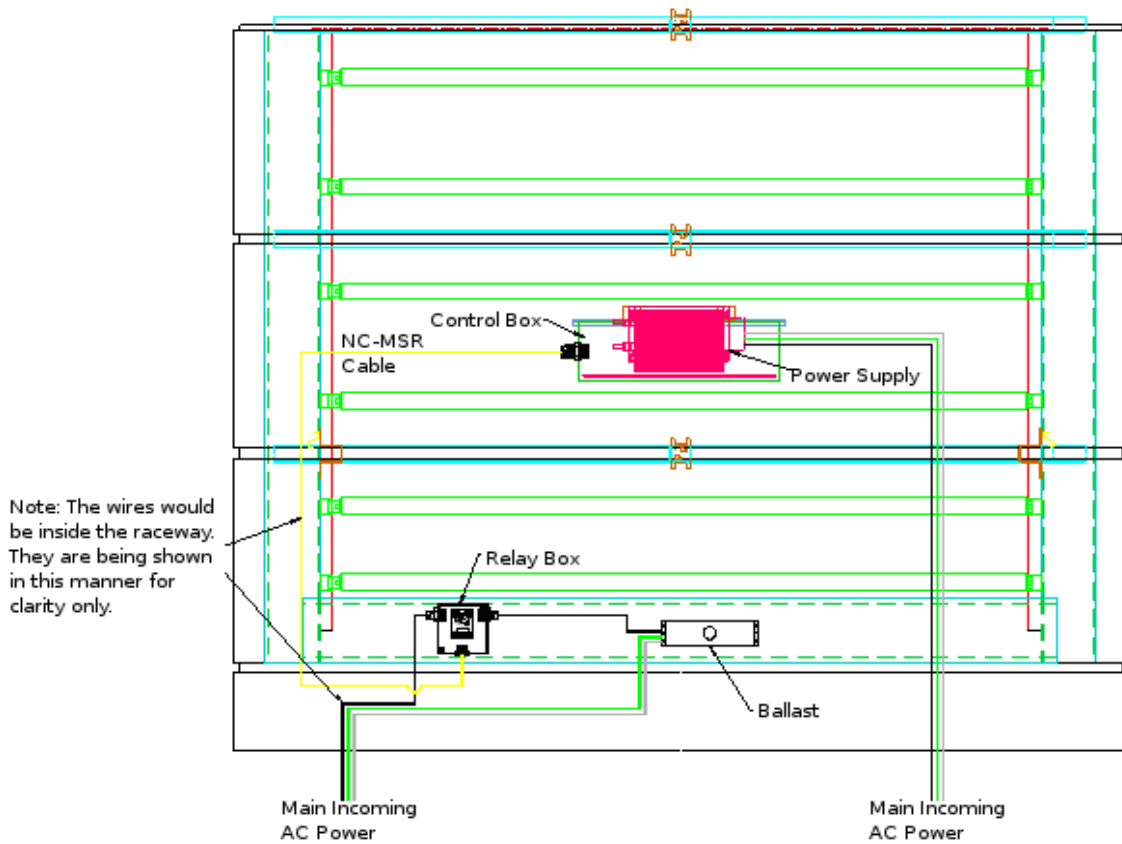


Figure 2: Interior layout

Mount the ballast relay J-Box where you can conveniently route the line side power wire that goes to the fluorescent lights through it (New Blair-built signs will have relay mounted). Cut the line side power wire to the fluorescent lights, and connect the cut ends to the ballast relay terminals labeled #1 and #2. Connect the two relay switching wires to the relay. The yellow wire connects to terminal #3, and the black wire connects to terminal #4. See Figure 3.

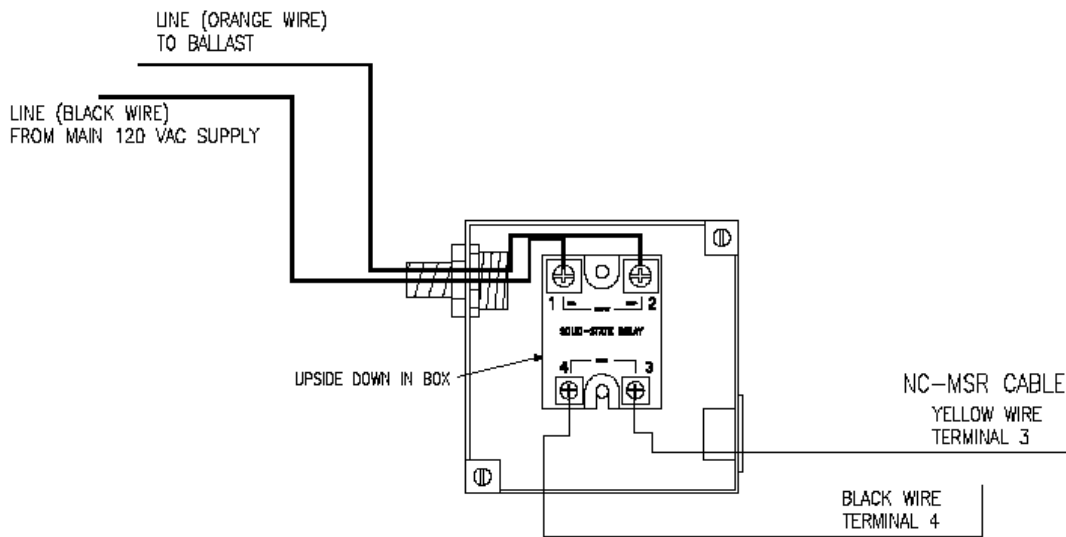


Figure 3: Relay connection. (Note: Diagram is for illustration purposes only; actual terminal layout may vary, but the labeling of the terminals remains constant)

Mount the LED control box inside the sign using provided mounting tabs (New Blair-built signs will have control box mounted). Connect the LED digits to the LED control box with the cables provided. The cable bundle is sealed; a plugged knockout is provided in the event replacement digit cables are required (Figure 4). **1st digit has green stripe; 2nd digit has yellow stripe; 3rd digit has orange stripe; 9/10's has white stripe.**

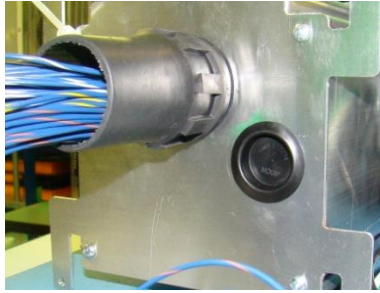


Figure 4: Plugged knockout for replacement digit cables.

Radio connection is provided with a radio connect fitting (Figure 5). Unscrew the fitting and slide the bushing and plug over the radio cable (Figure 6). Plug cable into fitting and tighten bushing. **DO NOT OVERTIGHTEN.** See Radio Installation Section I for details on different radio systems.

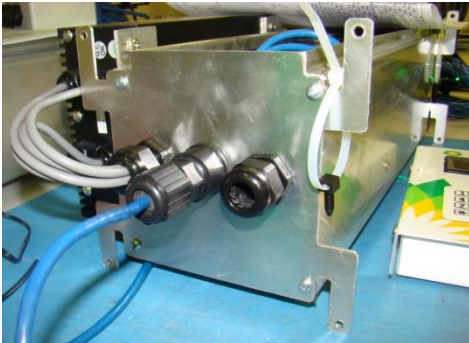


Figure 5: Radio connect fitting.



Figure 6: Connecting radio to fitting.

AVOID METAL SHAVINGS -- DO NOT DRILL INTO CONTROL BOX. Note that the control box must be mounted correctly to avoid damage. The control box should be hung from a support inside the sign so that the wires are not damaged. The control box must not be allowed to sit on the bottom of the sign. Finally, **DO NOT**, under any circumstances, modify the control box to make it fit into a sign. It is the installers' responsibility to ensure that the sign is weather-tight and that control box is mounted properly inside the sign.

For new Blair-built signs, including modular digits, the digits will be attached to new face panels.

To install LED digits onto the existing sign face:

Using the template that is supplied with the digits, carefully drill all of the necessary mounting holes and the holes for the electrical connections, according to the manufacturer's recommendations. (If you need extra templates, you can print more. Just go to <http://www.blaircompanies.com/ledsupport> and download the appropriate template for the size of your digits.) If the removal of any graphics is desired, that should be done before beginning the retrofit. The mounting hole diameter is 17/64in., and the connector hole diameter is 1in. The mounting hardware consists of 4 or 6 each #6/32 pan head stainless steel Philips screws, 1.5 inch long, #6 stainless steel flat washers, #6 stainless steel spring lock washers, and #6/32 stainless steel nuts or nut inserts.

If your sign has tracks, and the digits fit between the tracks, cover the area behind the digits with black vinyl according to the table in Fig. 12, and mount the digits with the supplied nut inserts. (It may be easier to cover the tracks with 3 inch vinyl, and then cover the area between the tracks with a third piece.) If the digits do not fit between the tracks, measure to see if the

track retaining tabs can be safely routed off to make room for the digit. We DO NOT recommend removing the track if it is adhered to the face as this may crack the face.

If the retaining tabs cannot be safely removed, or if this will not provide sufficient space for the digits, the digits can be mounted over the tracks. See Fig. 9 for details. (Because the digits have limited flexibility, and the digits will be damaged if flexed too far, spacers may be required behind the digits to prevent damage to the digits. **Any digit, which has been damaged because of improper installation, won't be covered under warranty.**)

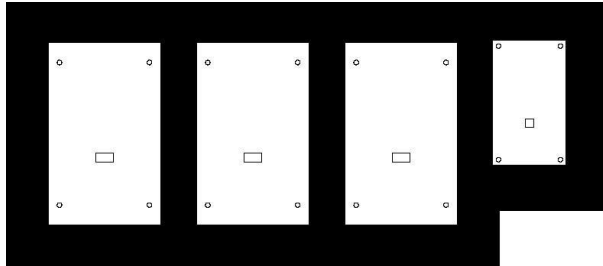


Figure 7: Vinyl and mounting hole template



Figure 8: Mounted digits

Black vinyl decal should be applied over the entire digit area before digits are installed, as shown. This provides better contrast and readability for the LED digits. (The table below lists our minimum recommended measurements, but it should be noted that more black area around the digits does improve legibility at larger distances.)

Lowest digit set is to have the BlairCompanies.com reflective white vinyl logo to be right justified below the rightmost LED digit. This could be '9', '9/10', or a full '8'. Refer to Section 'Q'. If individual panels are sent out from Blair, BlairCompanies.com logo will be attached to the lowest grade panel.

Digit Size	Space Between Digits	Left & Right Border	Top & Bottom Border	Between Rows
6"	1.5"	0.75"	0.60"	3.5"
9"	2.0"	1.00"	0.75"	5.5"
12"	2.5"	1.25"	0.90"	7"
18"	3.5"	1.75"	1.25"	10.5"
24"	4.0"	2.00"	1.50"	14"

Mount the LED digits on the sign face, being careful not to damage the digits by over-tightening the mounting hardware.

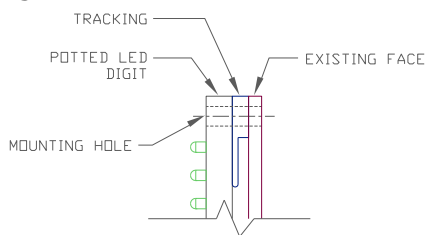


Figure 9: Correct mounting

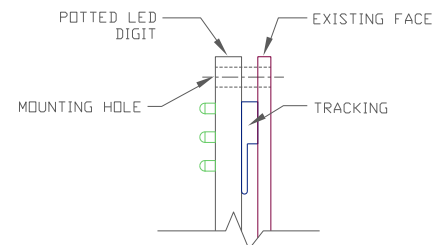


Figure 10: Incorrect mounting (Spacers required)

Blair ships a standard weather tight receptacle box, which the installer must install on the column of the sign within reach for the store operator to use. This is used to house the low voltage DC power cable the terminal will use while using the secondary communication method, and the secondary communication cable. The data cable is labeled "NC-SECONDARY" and is already installed in the control box (RS-232 port J18 of controller board) of the sign when shipped, as is the low voltage DC power cable. The installer must route these cables to the receptacle box during installation via conduit or behind the cladding of the sign. Ensure that proper orientation is observed; see Figure 10. Mount secondary box where it can be conveniently reached from the ground (typically around 4-5 feet above ground). If longer cable is needed, please order part number 33-31-17.

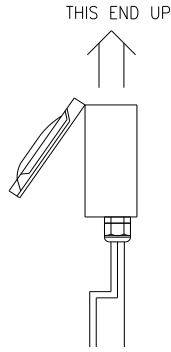


Figure 11: Orientation of receptacle box installation

Digit cables are color coded to aid in connecting drivers to digits: J12 & J16 are for the 1st digit of the price (Green stripe), J13 & J17 are for the 2nd digit of the price (Yellow stripe), J14 & J18 are for the 3rd digit of the price (Orange stripe), and J15 & J19 are for the 9/10ths digits (White stripe).

Modular Digits

For modular digits, each segment of the '8' is driven independently; one driver controls one digit. An additional tile such as a decimal or the '.9' can be driven as well. The digit cable will run to any one of the input terminals of each segment; all tiles in a segment are connected by jumpers. The segments are labeled according to Figure 12 (looking from sign face); labeled by segment and digit.

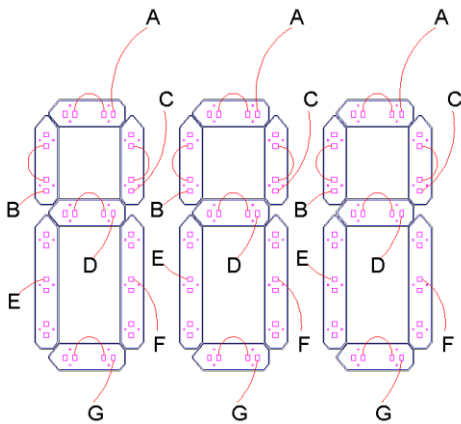


Figure 12: Modular LED digits wiring schematic



Figure 13: Modular LED digits wiring from behind face

Apply silicone around the plug on the back of the face to seal water away from the connection.

A plugged knockout hole is provided in Control Box endcap. Replacement digit cables will be provided with a Heyco bushing to run through this access hole in event of replacement.

Check all connections, and then apply power to the sign. The LED digits should light up. Set the prices to the correct values, and verify that the sign works properly. See Programming the Terminal Section J for details.

NOTE: Any deviation from the mounting instructions outlined here *will* result in damage to the control system. Because of this, our warranty on the control system is VOID if the control box is not mounted properly. The warranty will also be void if the control box is modified in any way.

H. Control Board Service

Installation does not require opening sealed control box. The following details connections inside the box in the event of servicing control board, power supplies, or driver boards.

Each driver board in the control box should be labeled with which price it controls. (Line1, Line2, etc.) If it is not, follow the cable plugged into J11 on the driver board back to the control board. On the control board, the cable will be plugged into one of six jacks, J1, J3-J7. J1 is for Line1, J3 is for Line2, J4 is for Line3, J5 is for Line4, J6 is for Line5, and J7 is for Line6.

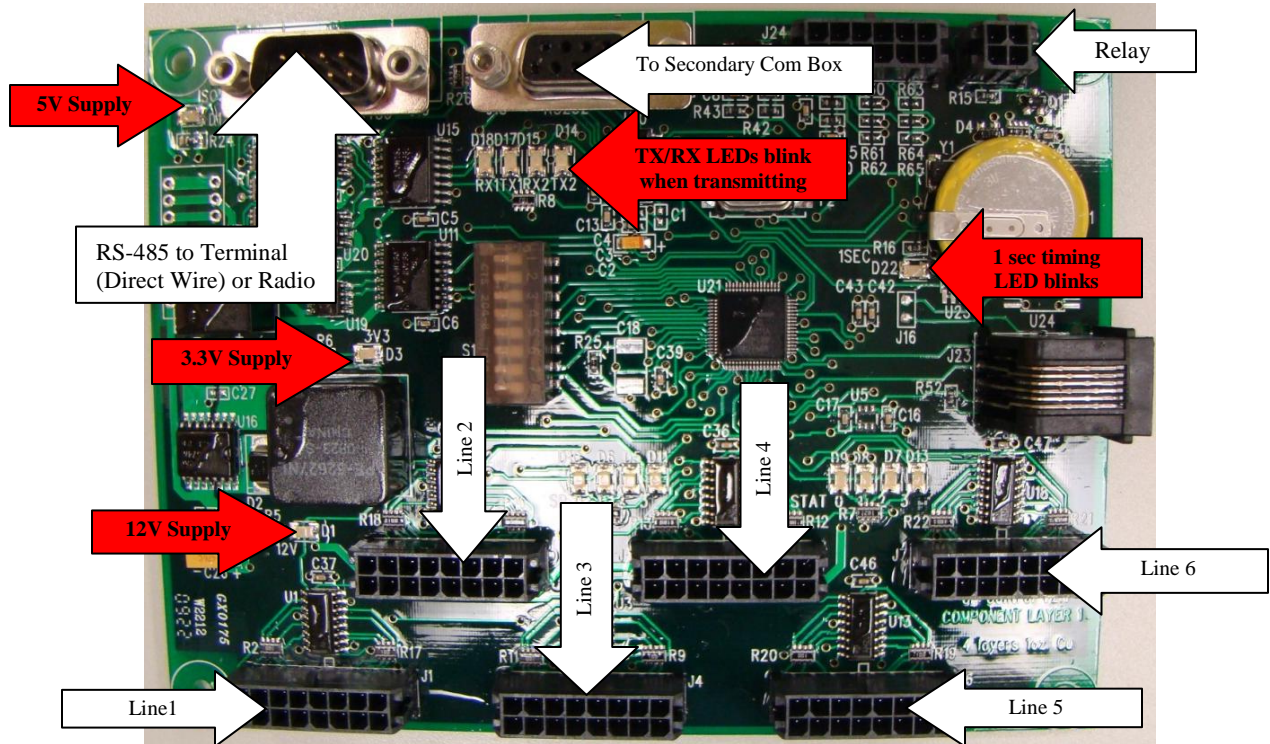


Figure 14: Controller Board (Grade names shown are example, specific to one brand)

On each driver board, there are eight jacks, four on each side (See Figure 15). These jacks are labeled J12 – J19.

The cables that connect each of the LED digits to their respective driver boards are run as follows: J12 & J16 are for the 1st digit of the price (Green stripe), J13 & J17 are for the 2nd digit of the price (Yellow stripe), J14 & J18 are for the 3rd digit of the price (Orange stripe), and J15 & J19 are for the 9/10ths digits (White stripe).

In the case of a modular digit, each segment is connected to one driver port of one driver board per digit.

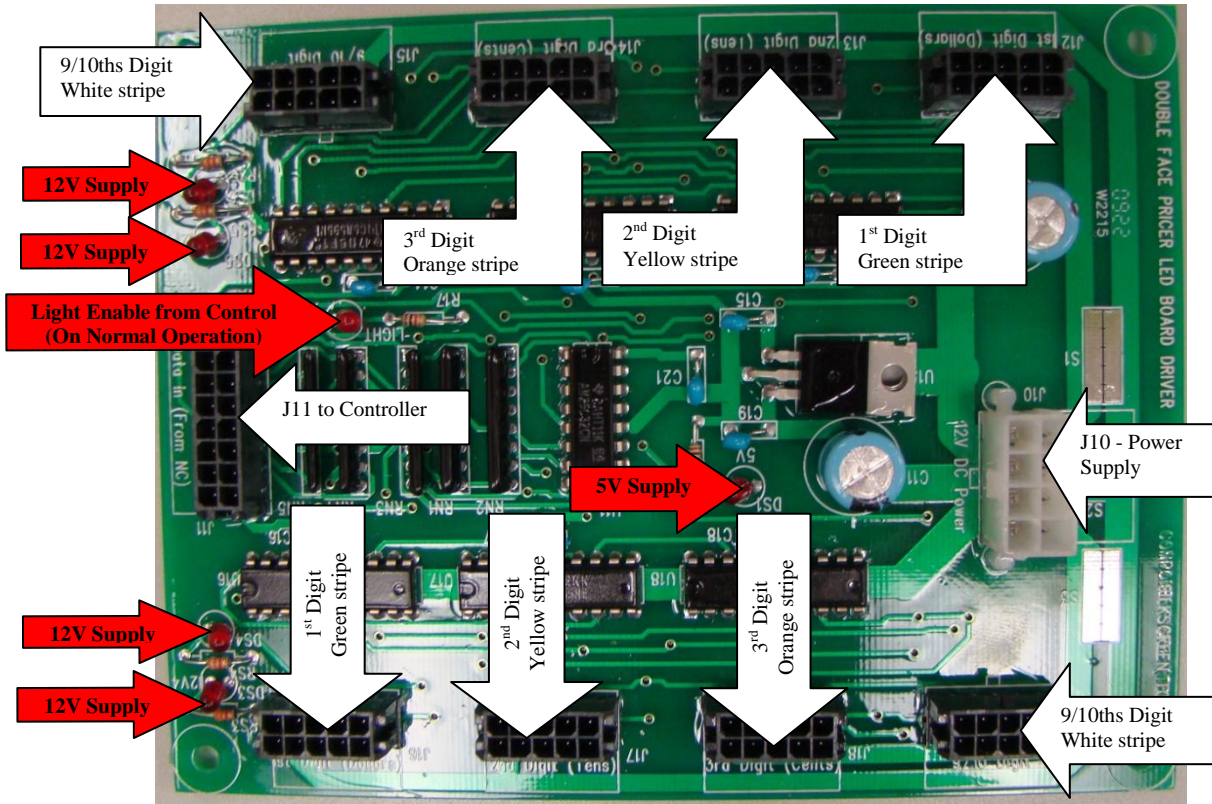
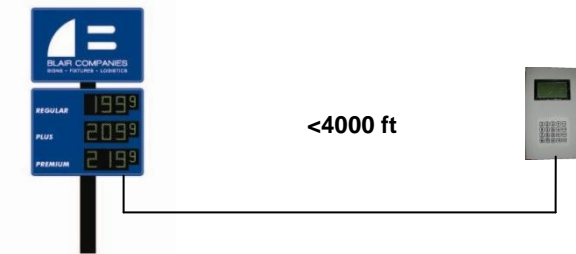


Figure 15: Driver Board

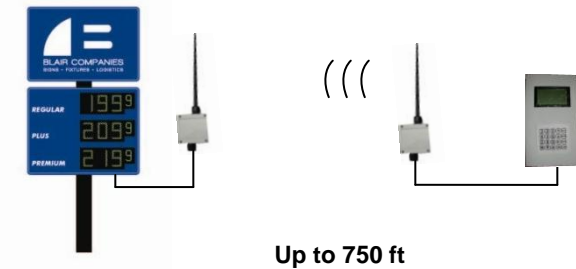
Note: The control board receives power from its connection to Driver1. If Driver1 is not properly connected to 12V supply, the control board will not power up.

I. Communication Methods



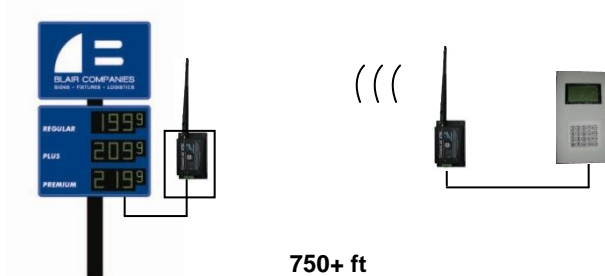
Direct Cable Communication

- Communicate from operator terminal inside store
- Kit includes terminal with display and all cables to connect to site-supplied CAT5 cable
- Most reliable, guaranteed connection
- Range up to 4000 ft



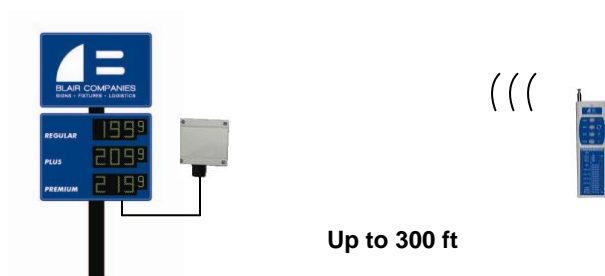
Standard Radio Communication

- Communicate from operator terminal inside store
- Kit includes terminal with display, cables, radio components, and enclosures
- Range up to 750 ft line-of-sight



Long-range Radio Communication

- Communicate from operator terminal inside store
- Kit includes terminal with display, cables, radio components, and enclosures
- Range 750+ ft line-of-sight
- Allows communication with multiple signs from single terminal



Economy Operator Terminal

- Simple 4-button handheld remote
- Kit includes remote and receiver components at sign
- Price change and settings displayed at sign
- Range up to 300ft line-of-sight

1. Direct Cable Communication:

- A. The preferred method of communication between the store and the sign.
- B. Requires a CAT5 cable to be run from the store to the sign (Note: The CAT5 cable is not supplied by Blair; it must be supplied by the installer). Blair supplies a 20' long cable labeled "GPT-NC". The installer will then cut this cable in the center and splice it onto the CAT5 wire between the store and the sign at both ends.
- C. All new build locations should use this method for communication. The direct cable method is effective up to 4,000 feet, assuming CAT5 wire is used.

2. Standard Radio Frequency Communication:

- A. Uses a pair of short-range radios to communicate from the store to the sign.
- B. Requires a direct line of sight between the store radio and the sign radio. (antenna must be vertical)
- C. Used in a retrofit location, or where installing a direct cable is not an option.

- D. **Not a guaranteed method of communication.** There are many outside factors that can have an effect on the operation of the radios. Things such as road construction, chain link fences, metal obstructions, and other radio frequency controlled devices can and do have an effect on signal strength. The short-range radios generally have a range of 750'. Refer to Parts List for a picture of a standard radio.

3. Long-range Radio Frequency Communication:

- A. Uses a pair of long-range radios to communicate from the store to the sign.
- B. Requires a direct line of sight between the store radio and the sign radio.
- C. Should be used when the standard radios fail, or when **two or more signs are at the same location**. If the two signs display the same grades, each will have its own control box and radio receiver (plus one radio at the terminal). If the two signs will display different grades, this **MUST BE NOTED WHEN ORDERING**. The control boxes will be unique to the signs, but user operation will be the same.
- D. Long-range radios are still not a guaranteed method of communication, but they have a greater range than the standard radios.
- E. The same things that can interfere with a standard radio can interfere with a long-range radio. There are many outside factors, which can effect the operation of the radio. Things such as road construction, chain link fences, metal obstructions, and other radio frequency controlled devices can and do have an effect on signal strength. However, because the long-range radios are more powerful, they can overcome interference that would not allow the short-range radios to work.
- F. The long-range radios have an operating range of up to a mile under "ideal conditions", but we recommend that they only be used up to a few hundred yards. Refer to Parts List for a picture of a long rang radio.

Note: As of September 4, 2007 long-range radio changed to a model that is not compatible with the model pictured in Figure 16. Take note of which one you have before calling for warranty returns or service. Aerocomm makes the current radio, and Maxstream or Digi made the old one.



Figure 16: First generation Long Range Radio. (Note: Requires weatherproof enclosure when mounted in a sign.)

4. Economy Operator Terminal:

- A. Uses a handheld transmitter and radio receiver to communicate from the store to the sign.
- B. Requires a direct line of sight between the handheld transmitter and the sign radio.
- C. Used in a retrofit location, or where installing a direct cable is not an option.
- D. **Not a guaranteed method of communication.** There are many outside factors that can have an effect on the operation of the radios. Things such as road construction, chain link fences, metal obstructions, and other radio frequency controlled devices can and do have an effect on signal strength. The short-range radios generally have a range of 300' – 500'. Refer to Parts List for a picture of transmitter and receiver.

5. Backup communication:

- A. Each sign is equipped with a secondary method of communication. In the event that the main communication method fails, the LED'S can still be controlled from the base of the sign with an Operator Terminal (P/N 320170). ***Economy Operator Terminal systems have this connection but are not supplied with the actual terminal. Blair certified technicians have spare components and can correct failure on site.**
- B. To use the secondary communication method, take the terminal from inside the store to the base of the sign and plug the power cable into the terminal. Next, pull out the data cable and plug it into the port on the terminal marked "RS-232". The terminal will then be able to communicate with the controller inside the sign. Now you can use the terminal to control the sign as you normally would from inside the store.

J. Radio Installation

Installation of the radios is the same regardless of which type of radio you are using. The only difference is that the long-range radio for the store does not come with a weatherproof box. The long-range radio for the sign will get a weatherproof ABS box.

Radio Guidelines For Best Performance:

1. The antenna on each radio must be vertical (up OR down).
2. The radio antenna at the sign must be mounted outside of the sign. Radio body can be inside, with antenna sticking out vertically.
3. **The radio must not come in contact with any moisture.** The standard radio at the sign is potted. Long range radios are supplied in a weatherproof box. It is the installer's responsibility to not alter the potting or box.
4. Radios in store should be placed near windows that face toward the sign whenever possible.
5. Antennas **must not** be located within 2.5' of other radio equipment and antennas.
6. The radio in the store should not be hidden. It is possible that the radio will work when hidden, but this is not reliable.
7. Finally, **do not mount radios inside of metal enclosures, or where metallic objects will be in line of sight between the two radios.** Doing so will seriously degrade performance.

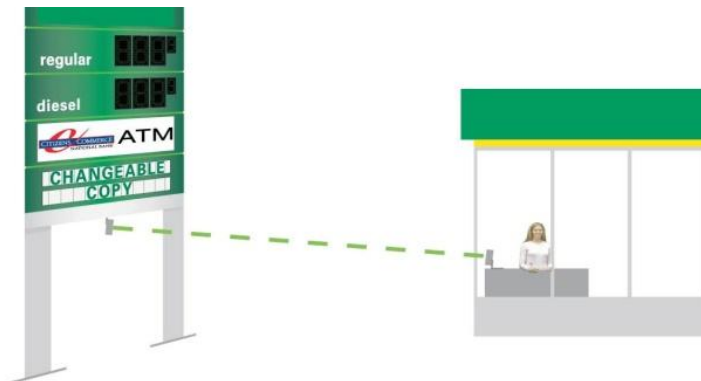


Figure 17: Radios mounted within line of sight and no obstructions

Radio at the Sign:

The radio at the sign is enclosed in an ABS plastic box with a 20' long cable. Radio can be mounted to leg or bottom of sign. If not desired to be visible, mount the radio with the antenna sticking outside of the sign. The free end of the cable must be plugged into the controller inside the sign. The installer must plug the cable into the port marked "RS-485" on the controller.

Note: The cable will only fit in one place on the controller.

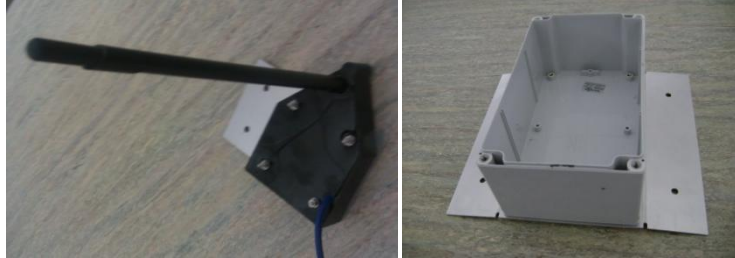


Figure 18: plates at sign for radio receivers—Potted (Left); Waterproof Enclosure (Right).

Radio in the Store:

If the radio is a standard unit, it will be potted. If the radio is a long-range unit, it will be supplied as a stand-alone radio module. A 6' standard Sub-D9 cable is supplied, but Sub-D9 extension cables are available at stores like Radio Shack. If an even longer run is necessary, CAT-5 cable can be used with the appropriate adapters, which are available from Blair, Mouser, Digi-Key, etc. The radio connects to the port marked "RS-485 To Sign" on the terminal. Terminal DC Power In must be plugged into supplied 12V transformer to operate.

K. Programming the Terminal

OPERATION INSTRUCTION DECAL LOCATED ON BACK OF TERMINAL BOX FOR REFERENCE.

The terminal box is located inside the store and is used to control the functions of the sign. It can be used to change the price of the LED digits and to turn the fluorescent lights on and off. (Note: Any changes may take up to 30 seconds to complete.)

If unplugged from 12VDC transformer, the terminal can neither change prices NOR control fluorescents through timers.

Changing the price of fuel:

To change the price of a fuel, use the button marked "Price" on the keypad to scroll through the different grades of fuel until you reach the grade you want. Once you are there, enter the new price on the keypad. Once you have entered the new price, you must press the "Valid" key to send the price to the sign. After the "Valid" key has been pressed, you may continue to the next grade of fuel to be changed. There are six different grades of fuel present in the terminal box (Line1, Line2, etc.). Be sure to change the correct grade; not all signs have all grades.

POS communication: The EPCU is capable of using the store POS system to automatically change price on the sign.

Gilbarco: To have the Gilbarco POS system change the price on the sign, install the cable marked POS-NC into the port of the stores computer marked "to sign", and the other end to the port on the terminal marked "POS/RS-232" using the supplied adapter.

Verifone: NOTE: Our system will only work if you have a Sapphire mini-server. If you have a Verifone POS system, install the cable marked POS-NC into one of the comm ports of the Sapphire mini-server on the "NEW PRO" board, and the other end into the port on the terminal marked "POS/RS-232" using the supplied adapter. Note: the comm port must be enabled for this feature to function.

The terminal should then change the price each time a new price is sent from the computer to the pumps. Note: The POS-NC cable must be specified at the time the sign is ordered, as well as the make and model of the POS system.

Dimming: Dimming of the LEDs is controlled by the terminal box's timers. These timers dim the LED brightness as well as simultaneously turning the fluorescent lights on and off. When the fluorescent lights turn on, the LED brightness changes to the nighttime setting, and when the fluorescent lights turn off, the LED brightness changes to the daytime setting. The times at which this occurs are controlled by the timer settings listed below. The brightness level can be changed by pressing the "Config" button until you see "Day*Night Light Level: 000-999". Enter the daytime and nighttime light levels, as a percentage of full brightness, where 000 is no light and 999 is full brightness. Then, hit the "Valid" key. The default setting is 999 & 500.

To manually control fluorescent lamps in the sign, simply press the "Light" key on the terminal box. This switch toggles between off and on. (Note: The word "light" will appear in the upper right corner of the terminal screen when the fluorescents are on.)

Timers: The operator terminal is capable of controlling the fluorescent lighting in the sign as well as the LED gas prices. This eliminates the need for a time clock from the installer. Do not install a time clock on the LED'S. Note: The hot (or line) lead for the ballast is switched by the ballast relay. The ballast relay must be connected as instructed (See Section C) for the fluorescent lights to be controlled by this system.

The terminal box's digital time clock and two internal timers are set to control all on/off timing. Figure 19 shows timer settings to control lighting, with the following example store:

EXAMPLE: Store opens 5AM, fluorescents on until 8AM, fluorescents back on 7PM, all off at station close at 11PM.

Timer 1 ON	Timer 1 OFF	Timer 2 ON	Timer 2 OFF
STORE OPENS	LIGHTS OFF FOR DAY	LIGHTS ON FOR NIGHT	STORE CLOSSES
0500	0800	1900	2300

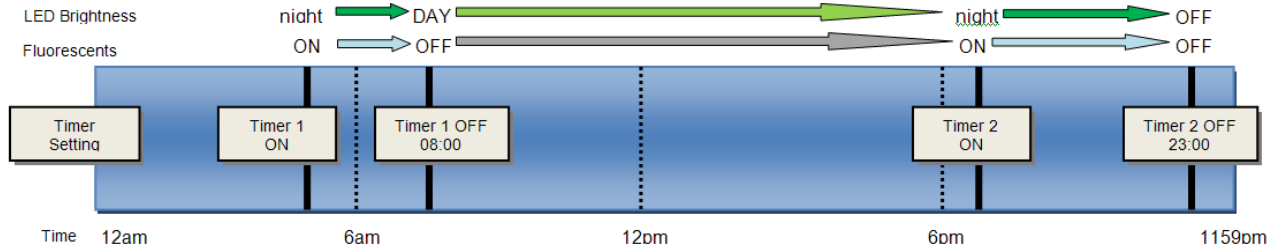


Figure 19: Timer usage diagram for two timers at store open 5AM-11PM

Timer 1 ON controls time to dim the LEDs to nighttime setting and fluorescents on (early morning).
 Timer 1 OFF controls time to turn LEDs to daytime setting and fluorescents off (daytime).
 Timer 2 ON controls time to turn on LEDs to nighttime setting and fluorescents on (evening).
 Timer 2 OFF controls time to turn LEDs and fluorescents off.
 When both timers 1 and 2 are set, the LED's will turn off between 2 and 1. This will not function properly unless Timer 1 is set before 12:00 and Timer 2 is set after 12:00.

To deactivate a timer set it's on and off time to the same time. For example, if Timer1 is set to turn on at 18:00 (6 PM) and off at 06:00 (6 AM), you wouldn't need Timer2, so you would set Timer2 On and Off to 08:01. Figure 20 shows operation for a **24hr open store** with lights on at 4PM and off at 8AM:

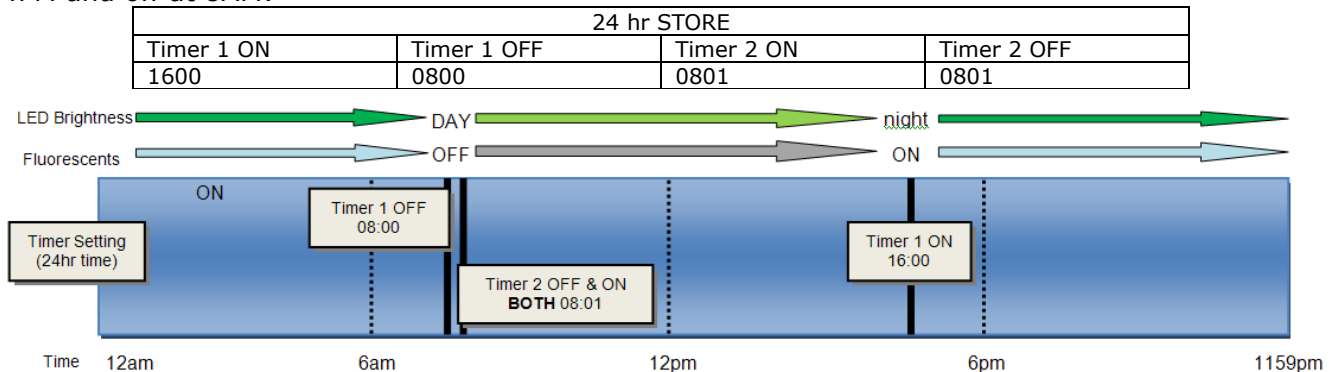


Figure 20: Timer usage diagram for single timer (24hr open store).

To activate the timers, they must be programmed by following the steps listed below:

Programming the clock with Operator Terminal:



Figure 21: Clock Programming Screen.

To program the real time clock press the "Config" button on the terminal box. The screen that appears will be the "set time" screen used to program the real time clock. Set the current time using a time scale of 24 hours in a day (00:00:00 to 23:59:59). Do not attempt to use AM and PM settings. The terminal will display AM and PM once you have entered the appropriate time from 1 to 24 hours. After the current time has been entered, you must press "Valid" to update your changes.

Programming the Date and Time with Operator Terminal:



Figure 22: Setting Date Screen.

To program the current date and time press the "Config" button twice to get to the "set date" screen to program the current date. Type in the current date including the year and press "Valid".

Programming the first timer with Operator Terminal:



Figure 23: First Timer Programming Screen.

To program the first fluorescent on/off timer press the "Config" button three times until you get to the "set timer 1 on" screen. Next enter the hour and minute you want the fluorescent lights to come on, and press "Valid". Next press the "Config" button again to get to the "set timer 1 off" screen. Enter the time you would like the fluorescent lamps to turn off, and press "Valid".

Programming the second timer with Operator Terminal:



Figure 24: Second Timer Programming Screen.

To program the second fluorescent on/off timer press the "Config" button five times until you get to the "set timer 2 on" screen. Next enter the hour and minute you want the fluorescent lights to come on, and press "Valid". Next press the "Config" button again to get to the "set timer 2 off" screen. Enter the time you would like the fluorescent lamps to turn off, and press "Valid".

L. Programming EMC Mini

Press the 'Config' button until 'This Product Shows on Line:' is displayed on the screen. Use the left and right arrow keys to scroll through the grades and the CASH/CREDIT combinations. For any one to display, press the pricer line to display it on. To remove a grade or CASH/CREDIT combination from the rotation, press '0' for that selection.

NOTE: Only grades and CASH/CREDIT combinations assigned to a line will be able to be selected to set a price. If a desired grade combination cannot be found in the price settings, it should be assigned a line in this mode.

To set the time each price is displayed, press 'Config' button until 'Set Display Time (00:SS)' is shown on the screen. Enter the time (in seconds) to display a price, then press 'Valid'.
Ex. To display prices for 5 seconds, at 'Set Display Time' press '0005', then 'Valid'.

Once complete press the "Price" button to exit the configuration mode. If at any point you want to exit the configuration mode press the "Price" button.



Figure 25: Terminal Communication Ports.



Figure 26: Operator Terminal.

M. Programming with Economy Operator Terminal

Timers are used with the same method above in Section J with the Operator Terminal. The Economy Operator Terminal is controlled with the 4-button handheld transmitter:



Figure 27: Economy Operator Terminal handheld.

On/Off switch: Switch ON to set prices or change settings

A button: Enter settings; from any setting mode, ends programming

B button: Select next setting

C button: Plus value; increments setting value up 1

D button: Minus value; increments setting value down 1

NOTE: The first time programming you will set the number of pricers. This will not have to be repeated.

The following is a list of programming steps and the code displayed on Pricer 1 (except other Pricer values). This list is also located on the handheld label:

<u>Programming step</u>	<u>Code displayed</u>	<u>Value meaning</u>
Pricer1 Pricer2 ↓ Pricer6	NNN NNN ↓ NNN	hh = hours 00-23
Fluorescents	Fon OR FoF	mm = minutes 00-59
Clock	Ahh	nn = value 00-99
Timer1ON	bmm	on = fluor on
Timer1OFF	Chh	oF = fluor off
Timer2ON	cmm	NNN = price 000-999
Timer2OFF	Hhh	
Daylight	hmm	
Nightlight	Jhh	SS = signs 01-06
NbPricers	Lmm	
	Uhh	
	umm	
	dnn	
	Enn	
	Pss	

The first digit of the code displayed is an indicator of which step you are on. For example if Pricer1 reads U11, that means the hour setting for Timer2OFF is currently set at 11.

NOTE: If at any point the system sits idle in a step for 20 seconds, it will reset to normal operation without storing that value.

Press the A/enter button to enter programming. Pricer 1 will flash. Increment the price up or down using C/plus or D/minus. To rapidly increment the price, hold the appropriate button down and it will begin to increment faster.

Press the B/select button to step to the next pricer. Repeat as above for this and all pricers. Press the B/select button to step to clock hours setting. Increment the time up or down using C/plus or D/minus.

Continue setting values for each setting by pressing the B/select button to step to each subsequent setting as mentioned above. Parameters are used the same way as described in Section I.

Set the number of pricer grades on the sign by scrolling to code Pss. Set the number of pricers 01-06, and press the A/enter button. This is important as it will disable the step for pricers (up to 6) that are not used, so there will not be extra button pushes or a blacked out board. If pressing B/select goes to a blank display, check that Pss is set to the appropriate value.

Turn off the handheld unit when not in use to save battery power. The handheld uses a standard 9V battery for power.

N. Troubleshooting

**Note: If you are unable to resolve the problem on your own, CALL BLAIR COMPANIES.
(See Contact List located in this manual.)**

See Schematics (Section P) for wiring diagrams and additional troubleshooting information

1. **Clearly define symptoms!!** This is the most critical step in troubleshooting. You must clearly understand the problem before you can attempt to solve it.
 - a. Is the problem unique to one digit?
 - b. Do the affected digit(s) on both faces display the same symptom?
 - c. Is the problem common to more than one fuel price, i.e. Line1 & Diesel?
 - d. Are the symptoms intermittent (They are not there all the time)?
 - e. If the symptoms are intermittent, what are the conditions when the problem is observed? Temperature, weather, and time of day can all be factors.

2. **If one or more of the digits on the sign are not lighting correctly:**
 - a. If the problem is located on a single digit only, the most likely causes are:
 - i. The digit itself. You can swap two digit cables easily at the driver board. If the problem stays where it was, either the digit or its cable is faulty. If the problem moves, try the driver board. If all else fails, try the controller board.
 - ii. The wire connecting the digit to the driver board. If you determined that either the digit or cable is bad in the step above, try changing the cable first. If that doesn't work, change the digit.
 - iii. The driver board. If you determine that the problem is NOT located in the digit or cable, replace the driver board.
 - iv. The controller board. If all else fails, change the controller board.
 - b. If there is more than one digit with the same problem, and they are all on the same driver board, the driver board becomes more likely as a cause, and you should change it first.
 - c. If there is more than one digit with the same problem, and they are NOT all on the same driver board, the controller board becomes more likely as a cause, and you should change it first.
 - d. If all digits display the same problem, it is almost certainly either the controller or the power supply, as those are the only parts common to all digits in the sign. Change the controller board first, and then try the power supply.
 - e. If all else fails, try swapping out the control terminal.

3. **If none of the LEDs are lighting:**
 - a. Make sure that the time, date, timer 1, and timer 2 are set correctly. The LEDs are supposed to turn off between timer 2 off time and timer 1 on time.
 - b. Verify there is adequate power to the sign. There must be 120v power to the sign at all times or the power supply will go into safe mode and shut down.
 - c. Verify there is nothing else on the circuit that powers the sign.
 - d. Check input and output voltage of the power supply. The Input should read 120VAC. The Output should read 12VDC.

4. **If the Sign is not Communicating Properly:**
 - a. Verify that the sign and operator terminal are powered properly.
 - b. Verify that the communications cable is connected to the terminal properly.
 - c. If you are using a long-range radio for communications, verify that the on/off switch on the radio has not been inadvertently turned off.
 - d. If you have a long range radio, and it has DIP switches, verify that the dip switches are set as follows:
Switch 4 should be on, all other switches should be off.

- e. Try the secondary communication method. Walk to the base of the sign and plug the terminal into the secondary communication port. If communication is successful, the sign controller and the terminal are functioning properly.
- f. If the secondary communication method works, there is a problem with either the radio system or the direct cable running to the sign.
 - i. Check the primary communication cable for cuts or other damage.
 - ii. If you have long-range radios, check the LED indicator lights. Green indicates power, red indicates transmitting, and yellow indicates receiving. Both radios need to be checked. The radios should flash red and yellow simultaneously.
 - iii. It is best to test the radios at a short distance to rule out a radio failure. To test the radios, unplug the terminal in the store and carry it out to the sign along with the radio. Plug the terminal power cord into the terminal and try to communicate with the sign. If the radios work over a short distance then the radios are working correctly, and the communication failure is being caused by outside interference.
- g. Check the indicator LED's on the terminal board and on the controller board.
 - i. There are small LED's on the terminal and on the controller that show the communication status of the circuit board. (This will require disassembly of the terminal box, and the sign to be opened by an experienced installer.) The indicator LED's for RS-485 should flash simultaneously for RX and TX on both the controller and the terminal. If either the TX or RX LED's are not flashing on the controller or the terminal it indicates a problem.
 - ii. If the terminal is transmitting (TX), but the controller is not receiving (RX) a signal from the terminal, there is a problem with the communication method or there is a terminal issue.
 - iii. If the controller is transmitting (TX), but the terminal is not receiving (RX) a signal from the controller, there is a problem with the communication method or there is a controller issue.

5. If the fluorescent lights in the sign do not turn on and off at the correct times, as set on the control terminal, verify that they are operating off of the control box, and not some other type of time management or other system.

- a. Verify that the on and off timers are set correctly on the terminal.
- b. If that doesn't work, change out the control board in the sign.
- c. If that doesn't work, change out the operator terminal.
- d. If that doesn't work, change out the main ballast control relay.

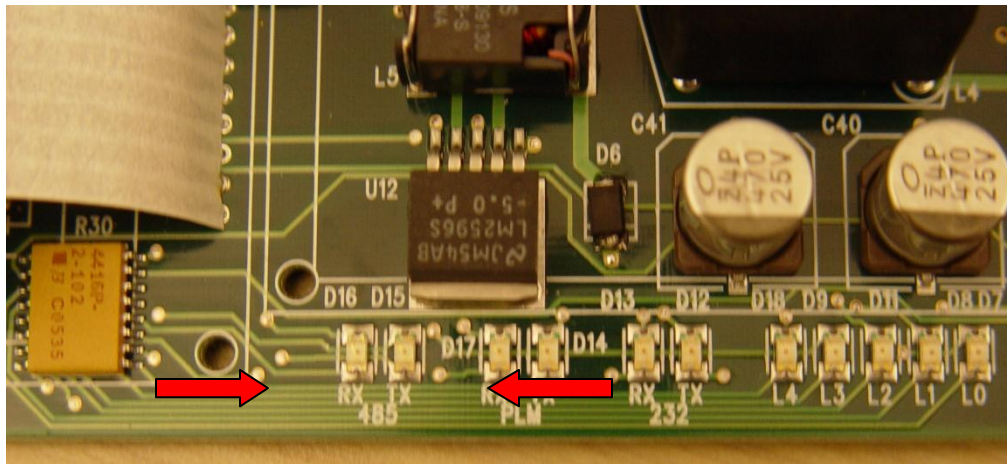


Figure 28: Indicator LED's on terminal

LEDs flashing:

Power supply having problem. This also affects fluorescent lamps.

- disconnect **all** devices. Check power supply(s) (120vac in, 12vdc out).
- connect driver board (check diagnostic LEDs (light enable does not light w/o control board)
- add control board (check diagnostic LEDs)
- with all digits disconnected, set all prices to 1.11
- reconnect digits one at a time. If all working, need additional power supply. Move one driver to this power supply.
- if still flashing, check secondary com box for water. Reconnect.
- if still flashing, check radio box for water and corrosion. Reconnect.
- if still flashing, check relay device. Reconnect.

Radio not communicating (terminal works):

- check dc power supply for terminal--should be 12v 1a minimum
- wireless routers @2.4ghz can interfere with short range radio

Problem communicating:

- orientation of both antennas should be same
- radio outside of sign?

Terminal screen blank:

- ensure blue wire grounded to case inside terminal box (fixed in all newer *terminals*)

Sign tripping breaker same time each day:

- check fluorescent timer. If same time setting as breaker trip, relay is wired wrong

Wrong price changes:

Order of connections at driver board incorrect

Wrong price displayed:

Check order of digit cables

Prices changing on their own:

Caused by interference. Any new BP stores in area? Any new radio transmitters or wireless routers?

- unplug radio. If stops, there is interference.
- Blair can provide custom radio for site to avoid the interference.

Segment out of multiple digits (same grade):

Likely driver problem. Exchange driver boards.

No LEDs lighting:

- check power at sign
- check timers at operator terminal
- check voltage at power supply (in 120vac, out 12vdc)

1,2,3,or 4 LEDs out:

Damage at board. Exchange digit.

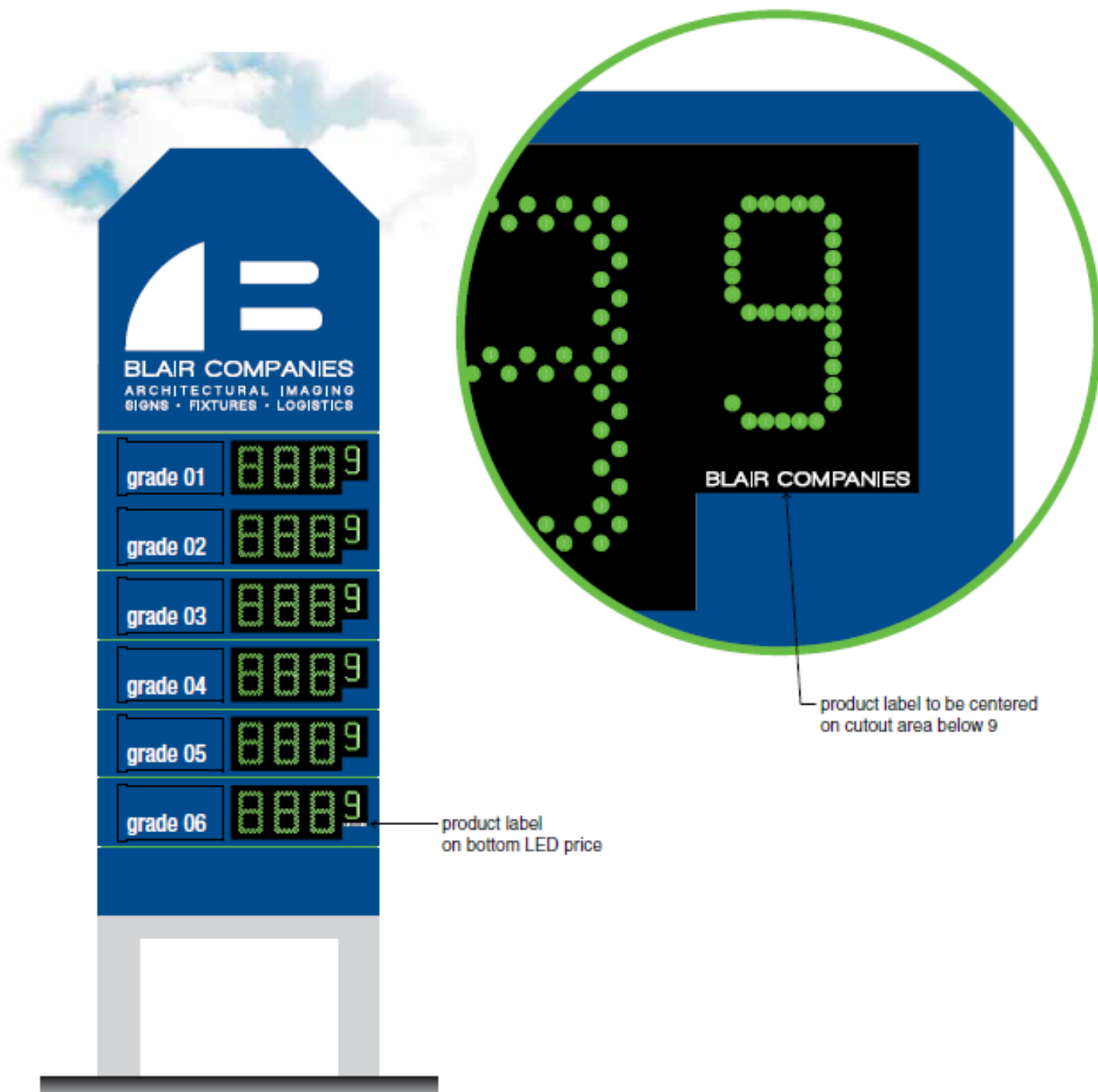
Segment out of single digit:

Likely cable problem. Exchange digit cables. If problem moves, replace cable. If not, replace digit.

O. BlairCompanies.com Logo Standards

BLAIR COMPANIES

blair companies product label



P. Completion Photo Guidelines

The following photos are necessary to verify proper installation and operation of the system. Note that digital cameras can capture images that may not reflect what is perceived by the human eye, particularly the LED display. This includes brightness/dimness or splotchy LED patterns. Take 2-3 photos of each required view, and check the picture on the camera to verify it reflects actual sign display. Camera settings like exposure setting may need to be increased to accurately portray the situation.

Email photos, along with job number/information to LEDWarranty@blaircompanies.com

- **Control Box** – How & Where the control box is mounted with silicone around the lid
- **Digit Cables** - Each Face showing back of plugs silconed
- **Grounding Rod** – Interior or Exterior
- **Radio in Store** – Must be in clear line of the sign. Mounted up or down **NOT** sideways or under cabinet
- **Radio on Sign** – Antenna must be mounted on exterior of sign up or down **NOT** sideways
- **Secondary Communications** – Must be mounted 4-5' off ground
- **Top of Sign** – Taken from Interior or Exterior showing sign is sealed and weatherized
- **Faces of Sign** – Showing LEDs are lighting on both sides of sign with NO outages. Photo needs to be taken from a distance of 5X height of display

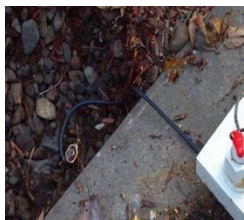
Sample photos



Control Box



Digit Cables



Grounding Rod



Radio in Store



Secondary Communication



Top of Sign



Face – Side 1



Face –Side 2



Radio on Sign



Radio on Sign



Q. REQUIRED WARRANTY & INSTALLATION CHECKLIST

Please complete one form for each location

SIGN OWNER

Company: _____
 Contact: _____
 Contact Phone: _____
 Store Address: _____

 Store Number: _____
 Sign Phone No.: _____
 (if applicable)

INSTALLER

Company: _____
 Phone: _____
 Address: _____

 Blair M#: _____

CONFIRM THE FOLLOWING ITEMS AS COMPLETED. Email or fax completed checklist, invoice, and photos to initiate the warranty. Send to LEDWarranty@blaircompanies.com or fax to 814-949-8293, Attn: LED Warranty.

- Sign Mounting: ***Please check with the owner or general contractor for any changes to the sign placement, height, or orientation before proceeding. Report any discrepancy from the plans.***
- Receipt of all required parts (sign, control box, keypad and radios)
- Receipt of all documents:
 - Instruction Manual (on web)
 - Operator Instruction Manual
 - Installation instructions for MID
- Upon completion of the installation, all manuals left with store manager or owner AND the site was trained on using the terminal box/key pad.
- Proper installation of all the following components is in accordance with Blair Companies' Installation Guide to assure that each component is operating properly. *(Please make note of any problems/resolutions on a separate sheet of paper and submit with this checklist.)*
 - Control Box
 - Terminal Box (key pad)
 - LED Digits
 - Grounding
 - POS Software & Cables (if applicable)
 - Sign/Panel mounting (if applicable)
 - Secondary Communication Cables - mounted 4 to 5 feet from ground level
 - Radios – Exterior radio mounted to exterior of sign; interior radio in line of site and away from potential electronic interference. All antennas located at least 2.5' away from other radio antennas.
- Each set of number modules is fully tested and operational.
- After installation, please send photos, invoice, and this form to Blair Companies. Photos must include the following:
 - **Control Box** – *How & Where the control box is mounted with silicone around the lid*
 - **Digit Cables** - *Each Face showing back of plugs silconed*
 - **Grounding Rod** – *Interior or Exterior*
 - **Radio in Store** – *Must be in clear line of the sign. Mounted up or down **NOT** sideways or under cabinet*
 - **Radio on Sign** – *Antenna must be mounted on exterior of sign up or down **NOT** sideways*
 - **Secondary Communications** – *Must be mounted 4-5' off ground*
 - **Top of Sign** – *Taken from Interior or Exterior showing sign is sealed and weatherized*
 - **Faces of Sign** – *Showing LEDs are lighting on both sides of sign with NO outages. Photo needs to be taken from a distance of 5X height of display*

INSTALLER: By signing, I agree that the sign described at the location above was installed according to the guidelines and that all items on the above checklist were completed. I understand that failure to perform any of the items on the checklist or to install per instructions will result in Installer liability. I also understand that in the event that additional work is required to properly install the sign, all incurred costs will be at my expense.

Installer Name: _____ Signature: _____
 Date of Install: _____

STORE MANAGER / OWNER: By signing, I agree that the installation of the sign described at the location above was demonstrated by the installer to be functioning correctly. The installer has reviewed the Installation Checklist with me and I agree that the installer has completed all items in accordance with the checklist.

Owner Name: _____ Signature: _____
 Date: _____

R. Contacts

Blair Companies
(800) 581-0709
service@blaircompanies.com

Hector Ortiz
(814) 283-2038
Cell (814) 934-8662
hortiz@blaircompanies.com

Christie Woods
Project Manager
(814) 283-2050
cwoods@blaircompanies.com

Kim Kurtz
(814) 283-2037
kkurtz@blaircompanies.com

Scott Hoffer
(814) 283-2036
Cell (814) 935-8506
shoffer@blaircompanies.com

Matthew Barton
Product Engineer
(814) 949-6419
mbarton@blaircompanies.com

**Blair Companies 24 hr Emergency Service:
800-563-9598**