

# Electronic Price Change Unit 3.0

## Installation & Configuration Instructions Revision 2.4

**Do Not** Leave this Document  
with Store Owners

**blair**

IMAGE ELEMENTS™

5107 Kissell Avenue

Altoona, PA 16601

814-949-8287

[www.blairimage.com](http://www.blairimage.com)

# WARRANTY INFORMATION

Note: This system converts a fluorescent gas price sign to an LED gas price sign. It is designed to be installed into a UL-48 listed sign only. The UL Listing Mark must be on the sign being retrofitted. Any other use is strictly prohibited.

**Warranty Terms: The warranty covers normal use and service. Damage caused by vandalism, lightning strikes, electrical surges, and any other acts of God, and any consequential or contingent liability is excluded from this warranty. Warranty claims must be registered with Blair Companies within thirty (30) days of damage or malfunction. Blair reserves the right to visit the site of the installation or to require documentation of the claim before assuming any responsibility under the provisions of the warranty.**

It is the installer's responsibility to provide a grounding rod for the sign.

Warranty coverage will not begin until the installer completes and submits the warranty card, installation checklist, and completion photographs. Please send these items within 30 days of installation to: [\*\*ledsupport@blaircompanies.com\*\*](mailto:ledsupport@blaircompanies.com)

## Cautions and Warnings

- LED signs are to be on a dedicated 120V - 277V AC, 20-amp circuit. This circuit should only operate the LED sign and any fluorescent or LED lighting in the sign connected through the AC distribution board. In the case an EMC is also on the same sign pole a second dedicated circuit is required for the EMC (Electronic Message Center).
- It is the installer's responsibility to ensure the sign is weather proof upon completion of the installation. This includes installing any lids and covers.
- Never run the LED portion of the sign off of a generator from a service truck.
- Always disconnect power from the sign before service.
- Bring sign specific wiring diagram.

# Table of Contents

## Part 1: Installation Instructions

- 1. Pre Install Checklist ..... 4
- 2. Components ..... 5
- 3. Power Requirements ..... 7
- 4. Retrofitting an Existing Sign ..... 8
- 5. Installation ..... 9
- 6. Connections ..... 12
- 7. Radio Installation ..... 18
- 8. Factory Reset / Switch Settings ..... 19
- 9. Multiple Control Boards ..... 20

## Part 2: Configuration and User Setup

- 10. Sign Configuration ..... 21
- 11. Economy Remote Binding ..... 26
- 12. Economy Remote User Menu ..... 27
- 13. Economy Remote Installer Menu ..... 32
- 14. Economy Remote Summary ..... 44
- 15. PricePad Operation ..... 45
- 16. Troubleshooting ..... 60
- 17. Maintenance ..... 63

# Section 1: Pre Install Checklist

## Part 1: Installation Instructions

- WARNING - Risk of fire or electric shock. LED Retrofit Kit installation requires knowledge of sign electrical systems. If not qualified, do not attempt installation. Contact a qualified electrician
- WARNING - Risk of fire or electric shock. Install this kit only in host signs that are UL listed and where the input rating of the retrofit kit does not exceed the input rating of the sign
- WARNING - Risk of fire or electric shock. Installation of this LED retrofit kit may involve drilling or punching of holes into the structure of the sign. Check for enclosed wiring and components to avoid damage to wiring and electrical parts.
- All team members on site must have a valid Blair Companies Certification Card and API Certification Card in their possession, as well as proper Personal Protective Equipment (PPE): Hard Hat, Safety Vest / Reflective Clothing, Long Pants, Work Boots (steel toed), Safety Glasses, and Gloves.
- Any non-crew member entering the work zone must be escorted at all times, and must wear a Hard Hat, Reflective Vest, and Safety Glasses.
- Appropriate barricades (48" minimum height, continuous) with caution signs must be used around the work zone at all times.
- There is to be no smoking, alcohol, drugs, or explosive materials on site.
- Check to make sure that all components are present. Refer to the sign specific configuration sheet and wiring diagram shipped along with these instructions.
- If any components are missing or damaged please contact Blair Companies prior to installation.
- Ensure that power has been provided to the sign via a dedicated 120V - 277V 20A circuit.

# Section 2: Components

## PricePad

(Includes Power Supply and Antenna)

POS Option	Part Number
No POS	LED00726
Verifone	LED00730
Gilbarco	LED00744
Passport	
NCR	LED00733

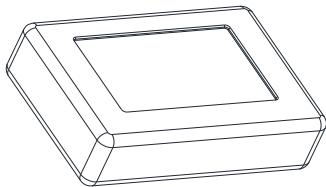

PricePad Power Supply  
 PricePad V1: 32-02-49  
 PricePad V2: 25-60-67



AC Distribution Board 120V – 277V  
 (v2.2) Part Number: LED00648

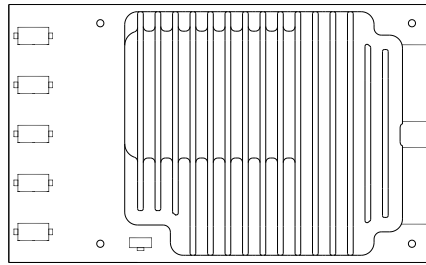

Digit Screw  
 6-32 x 1" Black Head  
 Part Number: 32-05-04



6-32 Nutsert  
 Part Number: 32-05-05

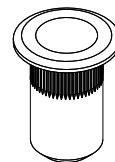

## Control Board

Type	Part Number
Master with Radio	LED00242
Master without Radio	LED00325
Slave	LED00261

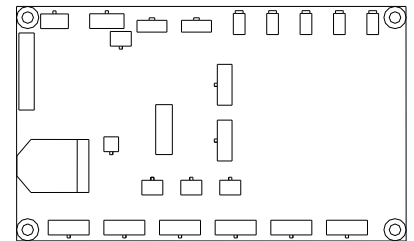

Power Supply 60W  
 Part Number: LED00243

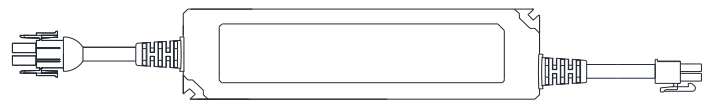

POS Com Cable	Part Number
Verifone	LED00727
Gilbarco Passport	LED00756
NCR	13-00-32

Economy Remote  
 Part Number: 32-01-89

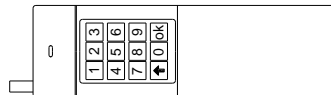

DIN Rail 2 meter  
 Part Number: 17-61-27



Antenna  
 Part Number: 32-20-03

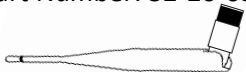

Antenna Cable 10 ft  
 Part Number: 32-03-22

Antenna Cable 20 ft  
 Part Number: 32-30-31

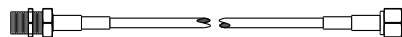

Text Display Green Part Number: LED00643  
 Text Display Red Part Number: LED00644

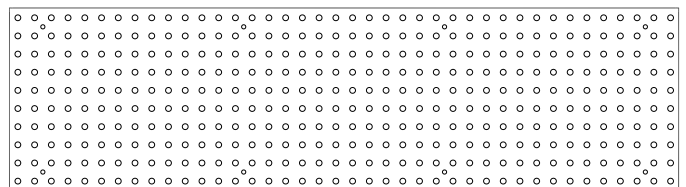

GPS Receiver  
 Part Number: 32-01-43

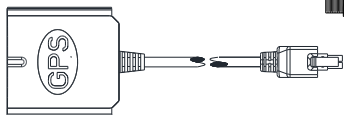

Digit Cable 10 ft  
 Part Number: 32-82-35

Digit Cable 3 ft  
 Part Number: 32-82-34



Relay/Decimal Cable  
 Part Number: 32-82-32



AC Power Cable  
 Part Number: 32-82-37



Controller Link Cable  
 Part Number: 32-82-36



Light Sensor  
 Part Number: 32-82-43

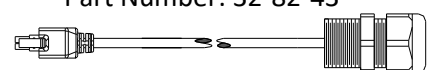

## Section 2: Components

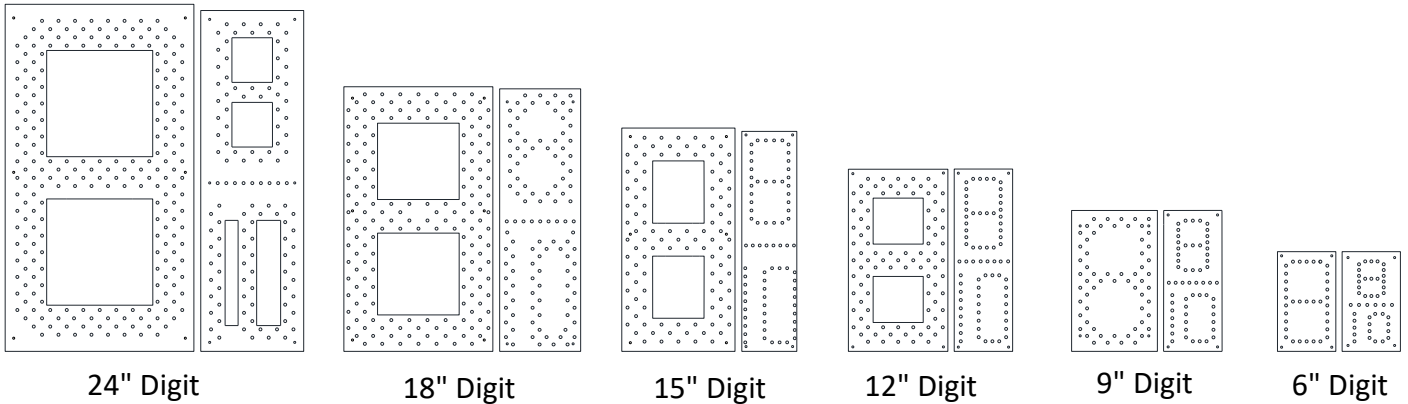

Digit Part Numbers					
	Green	Red	White	Amber	Blue
6" 7 Segment	LED00251	LED00494	LED00486	LED00584	LED00711
9" 7 Segment	LED00252	LED00495	LED00563	LED00585	LED00712
12" 7 Segment	LED00253	LED00496	LED00487	LED00586	LED00713
15" 7 Segment	LED00254	LED00497	LED00564	LED00587	LED00714
18" 7 Segment	LED00255	LED00498	LED00488	LED00588	LED00715
24" 7 Segment	LED00256	LED00499	LED00565	LED00589	LED00716
36" 7 Segment (half)	LED00892	LED00891			
6" 9/10	LED00502	LED00508		LED00590	LED00717
9" 9/10	LED00503	LED00509		LED00591	LED00718
12" 9/10	LED00504	LED00510		LED00592	LED00719
15" 9/10	LED00505	LED00511		LED00593	LED00720
18" 9/10	LED00506	LED00512		LED00594	LED00721
24" 9/10	LED00507	LED00513		LED00595	LED00722
Decimal 9" - 15" digit	LED00515	LED00517	LED00492	LED00805	LED01602
Decimal 18"- 24" digit	LED00516	LED00518	LED00493	LED00898	

Install Kit for 1 line of digits (4 digits)				
Includes: Paper Pattern, Vinyl Layout, Mounting Hardware				
	Small 9 no Decimal	Small 9 Decimal	9/10 no Decimal	9/10 Decimal
6"			LED00609	
9"	LED00679		LED00610	
12"	LED00680		LED00611	LED00684
15"	LED00681		LED00612	
18"	LED00682		LED00613	LED00706
24"	LED00683		LED00614	

# Section 3: Power Requirements

Complete the table below to find the maximum power draw of the sign, number of power supplies required, and primary AC draw.

## Power Consumption Per Line

(4 digits with standard small 9's)

Digit Size	Red / Amber	Green / White / Blue
6"	14 watts	14 watts
9"	22 watts	27 watts
12"	26 watts	32 watts
15"	29 watts	34 watts
18"	42 watts	52 watts
24"	57 watts	69 watts

	Power Draw per Line	Number of Faces	Total Power Draw
Product 1	_____	x _____ =	_____
Product 2	_____	x _____ =	_____
Product 3	_____	x _____ =	_____
Product 4	_____	x _____ =	_____
Product 5	_____	x _____ =	_____
Product 6	_____	x _____ =	_____
Product 7	_____	x _____ =	_____
Product 8	_____	x _____ =	_____

**Total Power of Sign** \_\_\_\_\_

Power Supplied by Control Board	Number of Power Supplies Required	Primary AC Draw at 120V
0 - 35 watts	1	0.8 Amps
36 - 108 watts	2	1.6 Amps
109 - 162 watts	3	2.4 Amps
163 - 216 watts	4	3.2 Amps
217 - 270 watts	5	4.0 Amps

Sign voltage rating 120 - 277VAC 50/60Hz

**Note:** If more than 270 watts are required, a slave controller board must be used. If multiple controllers are used, the number of power supplies must be calculated on a per controller basis. To calculate the number of supplies, consider the number of lines attached to each controller.

## Section 4: Retrofitting an Existing Sign

*The following instructions apply when an EPCU is to be installed in an existing UL Listed sign. The EPCU can be used to replace traditional fonts as well as any existing electronic flip sign or LED gas price sign. Minimum dimensions for the sign body are 9.25" High by 23.5" Wide by 4" Deep*

### 4.1 PREPARING OLD SIGN:

- a) Remove any existing fonts and retainers.
- b) Clean any debris from the inside of the sign cabinet.
- c) Install the new sign face. If the existing sign face is being reused, place the supplied black vinyl over old font openings.
- d) Ensure that a 20 Amp disconnect switch is installed.
- e) Repair and seal any unused openings in any rain enclosures. Openings greater than 12.7 mm (1/2") diameter require a metal patch secured by screws or rivets and caulked with non-hardening caulk. Smaller openings may be sealed with non-hardening caulk.

Note: This system converts a fluorescent gas price sign to an LED gas price sign. It is designed to be installed into a UL-48 listed sign only. The UL Listing Mark must be on the sign being retrofitted. **Any other use is strictly prohibited.**

# Section 5: Installation

## 5.1 DIGITS

- a) Digits should be mounted on the outer sign face. They should not be mounted behind a plastic face.
- b) Use the template supplied with the digits to mark where mounting holes should be drilled. The paper template should not be drilled through because in most cases it must be reused for multiple lines of digits.  
(If additional templates are required printable files can be found at <http://www.blaircompanies.com/ledsupport>)
  - The mounting hole diameter for nutsert is 17/64".
  - The connector hole diameter is 1-5/8".
- c) Install nutserts in the digit mounting holes.
- d) Mount the digits in correct orientation using the supplied screws. Use hand tools to tighten the screws to avoid over tightening which will cause damage to the digit.

**If face material is plastic less than 0.040 inches thick a backer panel is required to stiffen the face.**

**Ensure digits are in the correct orientation before mounting. "EPCU 3 TOP" is stamped on the top back of each digit.**

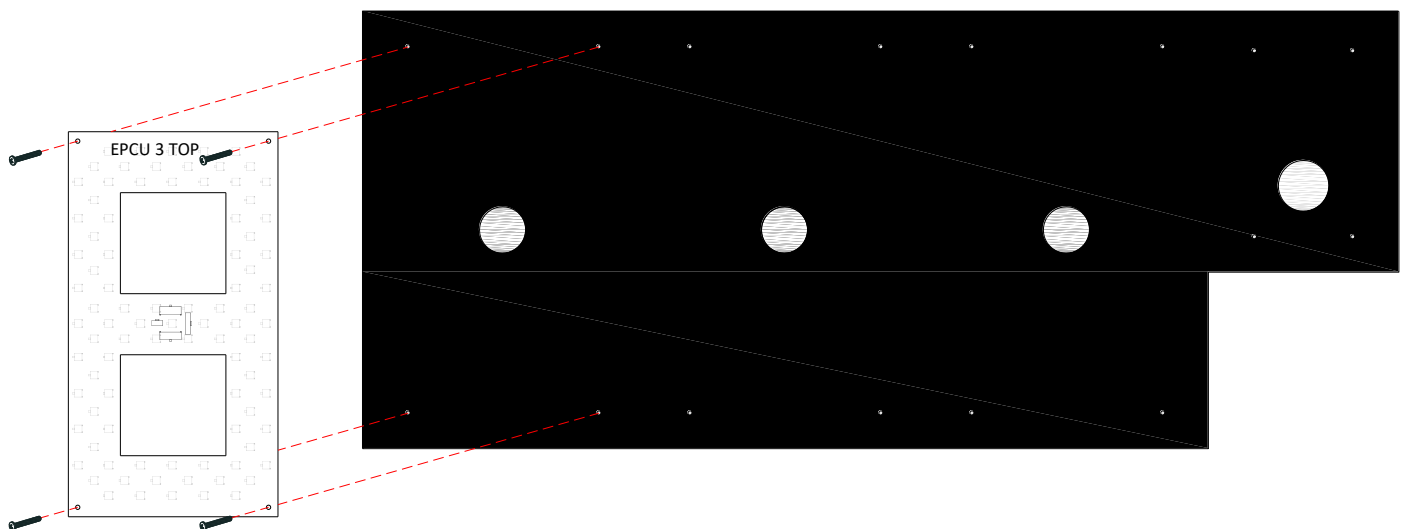

# Section 5: Installation

## 5.2 SYSTEM MOUNTING RAIL

### Typical DIN Rail Installation

All of the Control System components will mount to this rail via specialized clips which will make installation and maintenance easy.

- Mount the DIN Rail between lamps and center it vertically over all digits.
- Use self-drilling / self-taping screws. (Not Included)
- Position the DIN Rail such that a **minimum clearance of 5 inches** is present between the front of the rail and the sign face.

DIN Rail can also be mounted vertical if horizontal mounting is not practical.

If mounted vertically notches must be bent into the rail to prevent components from sliding down.

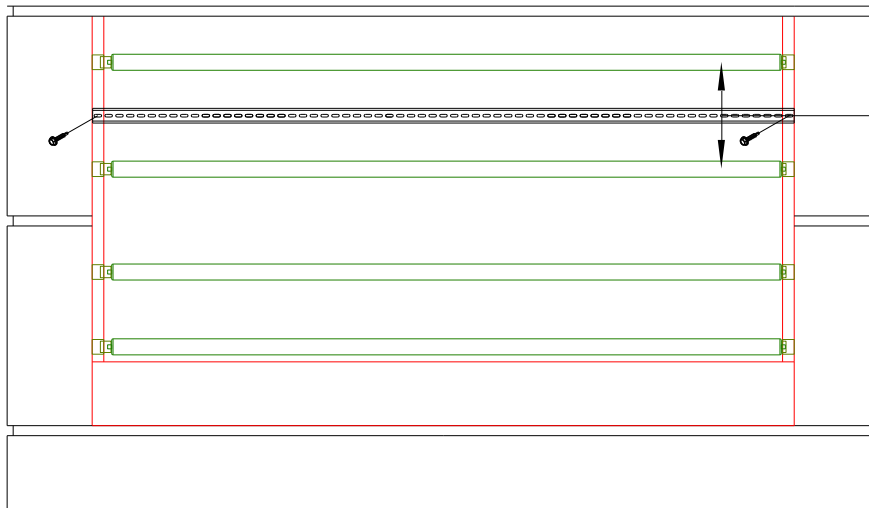

CENTER DIN RAIL BETWEEN LAMPS

## 5.3 MOUNTING POWER SUPPLIES

- Place the power supplies on the DIN rail.
- Power supplies should clip onto the DIN rail easily.
- Ensure there is a minimum of 2 inches between all components on the DIN rail.

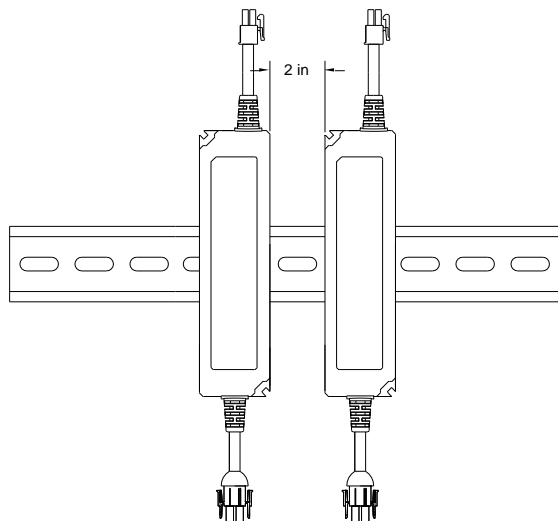

# Section 5: Installation

## 5.4 AC DISTRIBUTION BOARD

- a) Mount the AC Distribution Board onto the DIN rail to the right of power supplies.
- b) Mount the AC junction box onto the sign frame within 6 feet of the AC Distribution Board.
- c) Ensure there is a minimum of 2 inches between all components on the DIN rail.

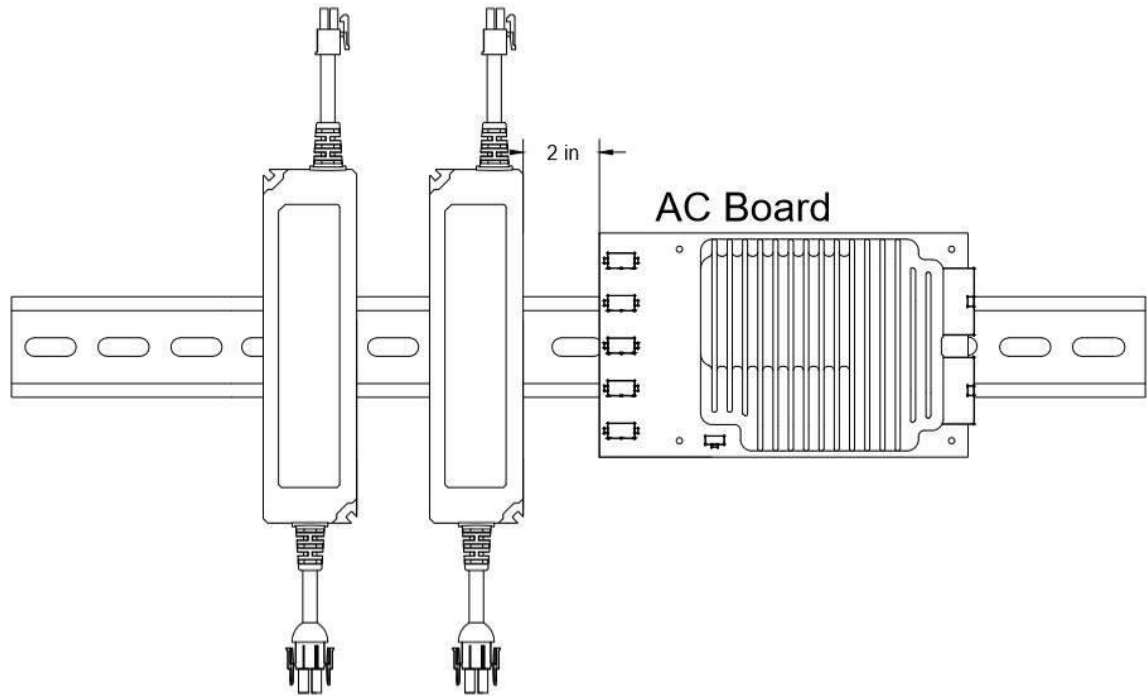

## 5.5 CONTROL BOARD

- a) Mount the Control Board on the DIN rail to the left of the power supplies.
- b) Ensure there is a minimum of 2 inches between all components on the DIN rail.

Ensure all components are mounted in the orientation shown in drawing.

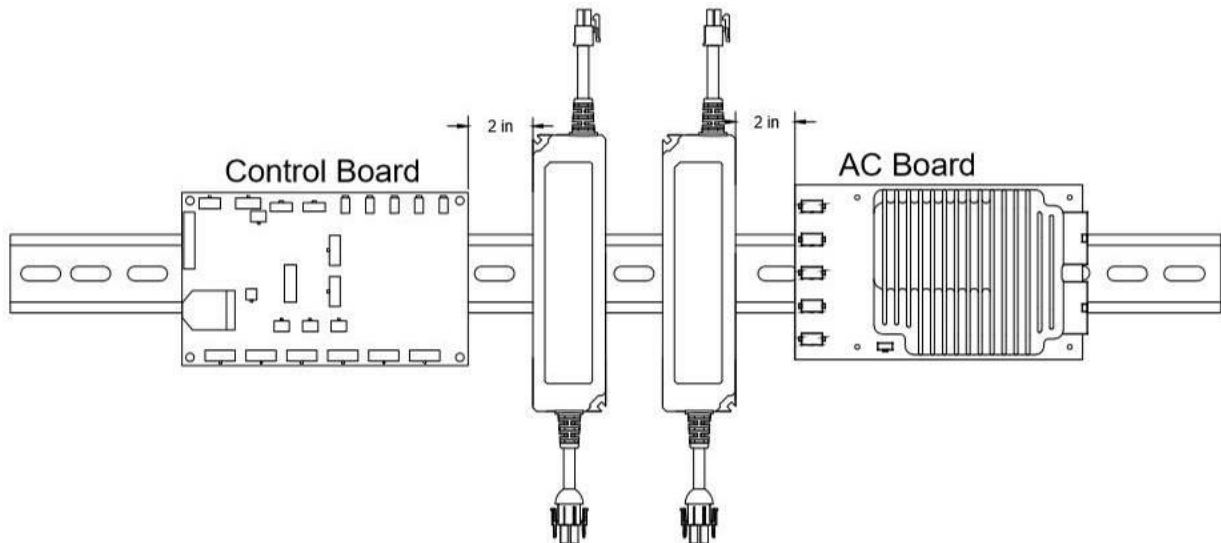

# Section 6: Connections

## 6.1 Power from AC Board

- a) Connect the power supplies to the output connectors on the AC Distribution Board.
- b) Ensure that all unused connectors on the AC Distribution Board are covered with caps.

**Make sure that all connections have drip loops, so that water does not enter the connector.**

**Ensure that all unused connectors on AC distribution board are covered with caps.**

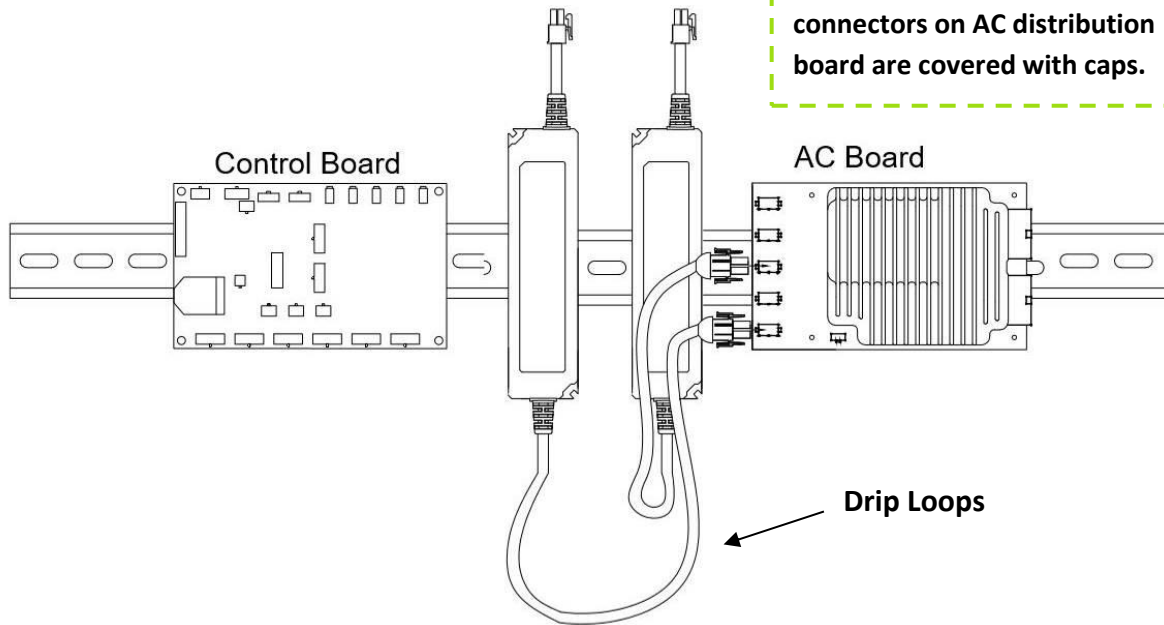

## 6.2 Power to Control Board

- a) Plug the power supplies into the control board. Use every other channel if possible (3 or less power supplies required).

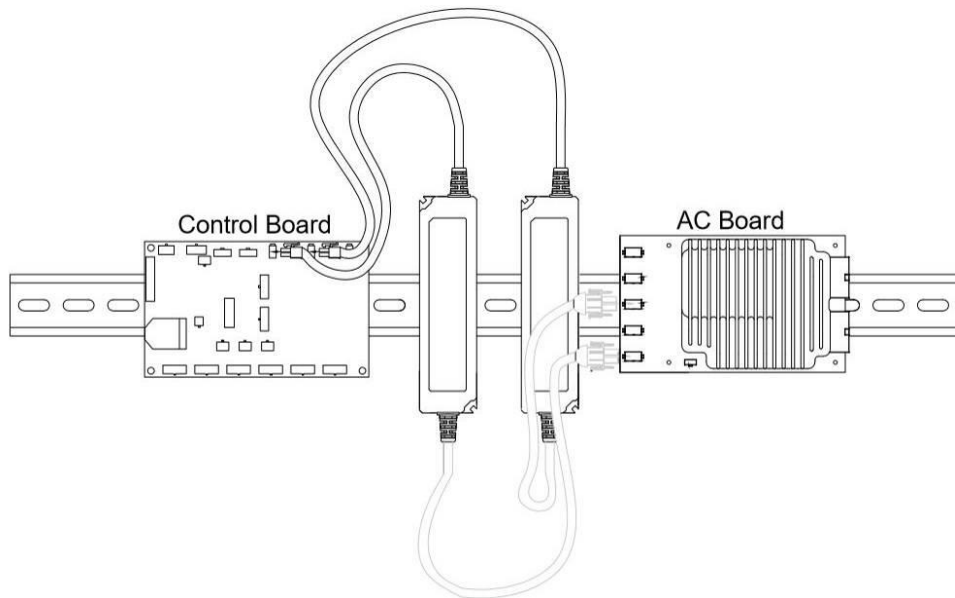

## Section 6: Connections

### 6.3 Relay Cable (If Equipped)

- a) Use the Relay/Decimal cable to connect the Control Board to the AC Distribution Board to operate the relay on the AC Distribution Board.

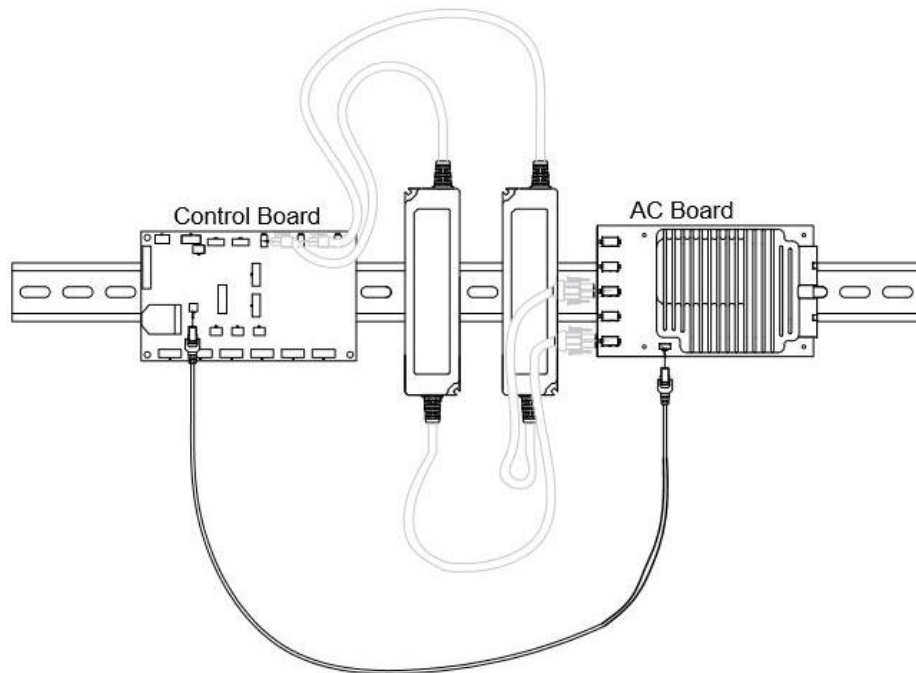

### 6.4 AC Board Power Connections

- a) Use the AC power cable to bring power into the AC Distribution Board (top left connector).
- b) Connect the fluorescent lamp ballast using the AC power cable (top right connector) (This allows the Control Board to turn the lamps on and off).

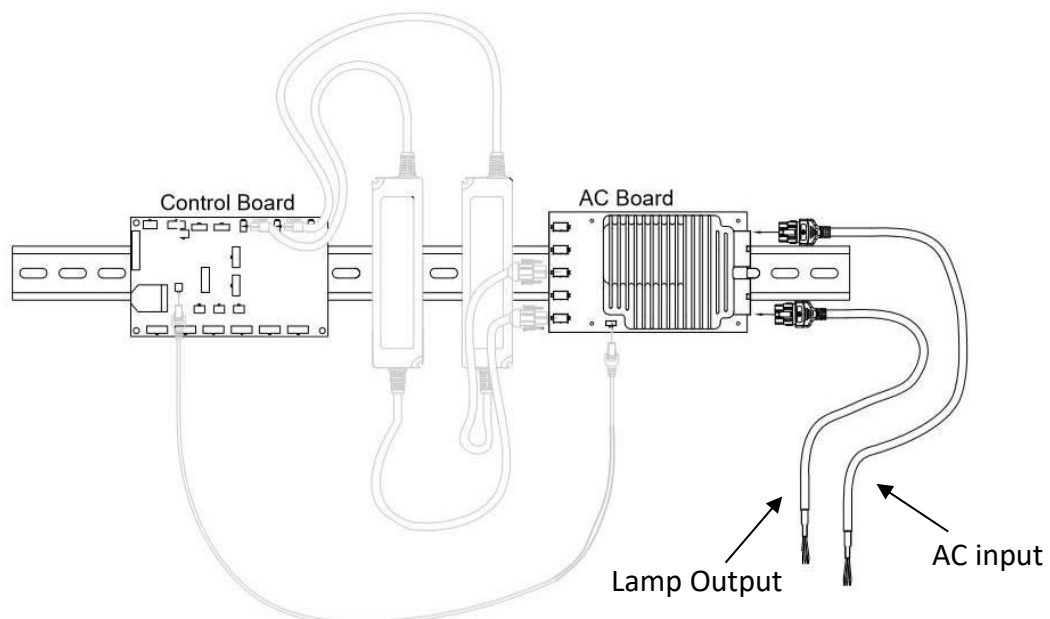

# Section 6: Connections

## 6.5 Connecting the Digits (refer to "Section 9: Sign Configuration")

- a) Use the long (10') digit cable to connect the Control Board to the first digit on line one.
- b) Use the short (3') digit cables to connect between digits.
- c) Reference the included **sign specific Digit Wiring Diagram** and **Control System Wiring Diagram** before connecting digits.

The data connections on the back of each digit do not have a specific in and out.

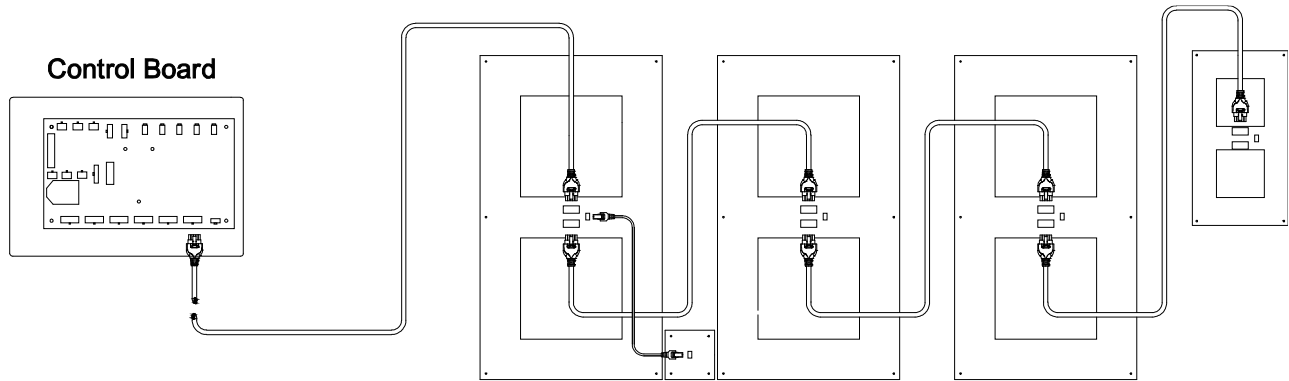

## 6.6 Junction Box

- Electrical grounding requires a minimum dedicated 1/2" x 8' copper grounding rod connected to a #8 gauge copper grounding wire which connects to the supply line ground. (Grounding rod and wire are not included with the sign).
  - \* Do not use aluminum grounding rods.
- Follow all national electrical codes along with local regulatory codes.

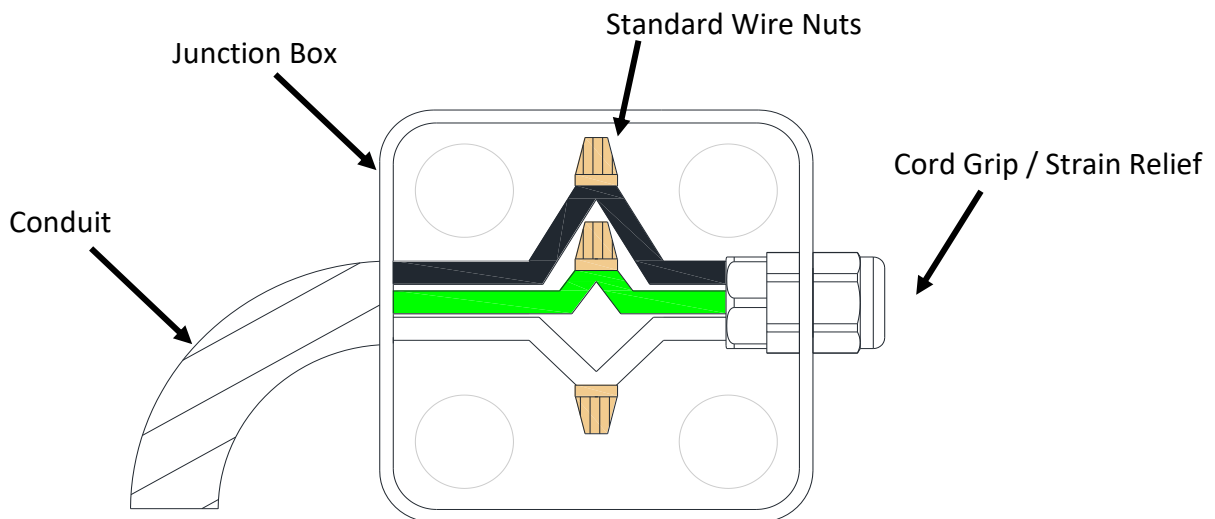

## Section 6: Connections

### 6.7 Antenna Installation (Required for PricePad communication)

- Connect the antenna cable to the blue XBee on the master Control Board.
- Route the antenna cable to the exterior location where the antenna will be mounted.  
(The antenna must be located on the side of the sign facing the store or location where the PricePad will be used. Line of sight to store side radio is ideal.)
- Drill a 1/4" hole in the sign for the male side of the antenna cable.
- Put the end of the cable through the hole and install the nut on the exterior of the sign to hold the cable in place.
- Attach the antenna and position it vertically (up or down).

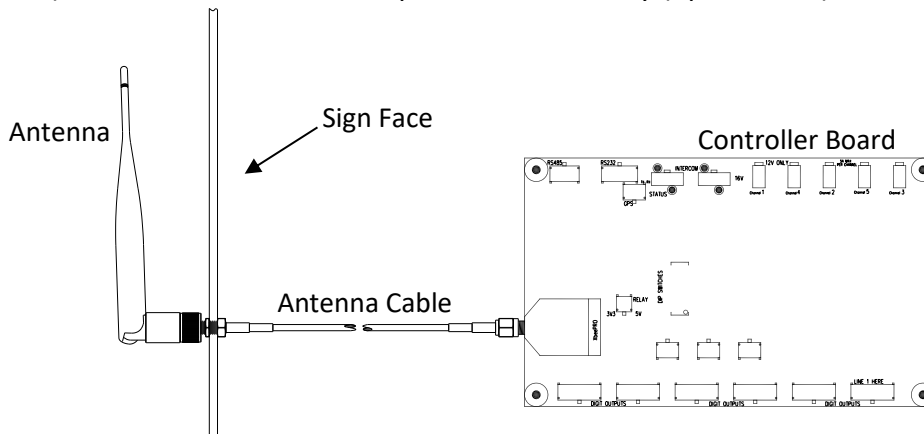

### 6.8 Sensor Installation (If Equipped)

#### GPS Receiver

- The GPS receiver is magnetic and should be attached to a painted piece of metal with direct view of the sky.
- Route the GPS Receiver cable to the controller board and connect it to the GPS input.

#### Light Sensor

- Locate a position for the light sensor facing down and away from light sources where the 12 ft cable can reach the controller board.
- Drill an 11/16" hole for the light sensor.
- Mount the light sensor and route the cable to the controller board.
- Connect the light sensor to any of the 3 light / temperature sensor inputs.

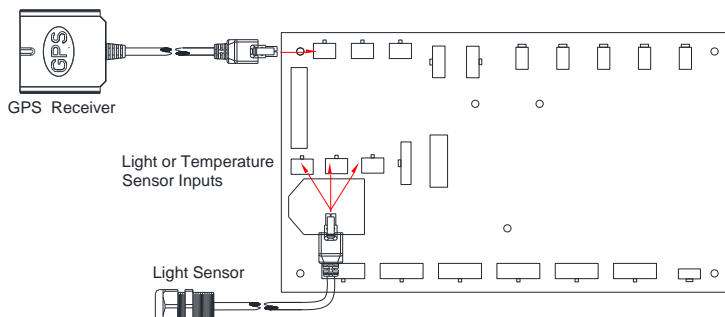

## Section 6: Connections

### 6.9 Text Display Installation (If equipped)

A text display can consist of between 1 to 8 LED tiles. The display can be used to indicate a payment method (Cash and Credit) or a product name (Regular, Plus, Premium).

#### Wiring guidelines

The LED tiles that form the text display are connected to the digit outputs on the controller board.

- 1 to 4 tiles can be connected to one digit channel on the controller board.
- Tiles should be connected to the next available digit output (going from right to left on the controller) after all digits are connected.
- Multiple displays can be chained together as long as the total number of tiles chained does not exceed 4.
- Any display size other than a single tile or a 2 x 2 tile display will require configuration. See *display settings* in section 12 of the manual for configuration information.

#### 2x1 Display Wiring

- a) Use the long (10') digit cable to connect the Control Board to the first LED tile.
- b) Use the short (3') digit cable to connect between LED tiles.

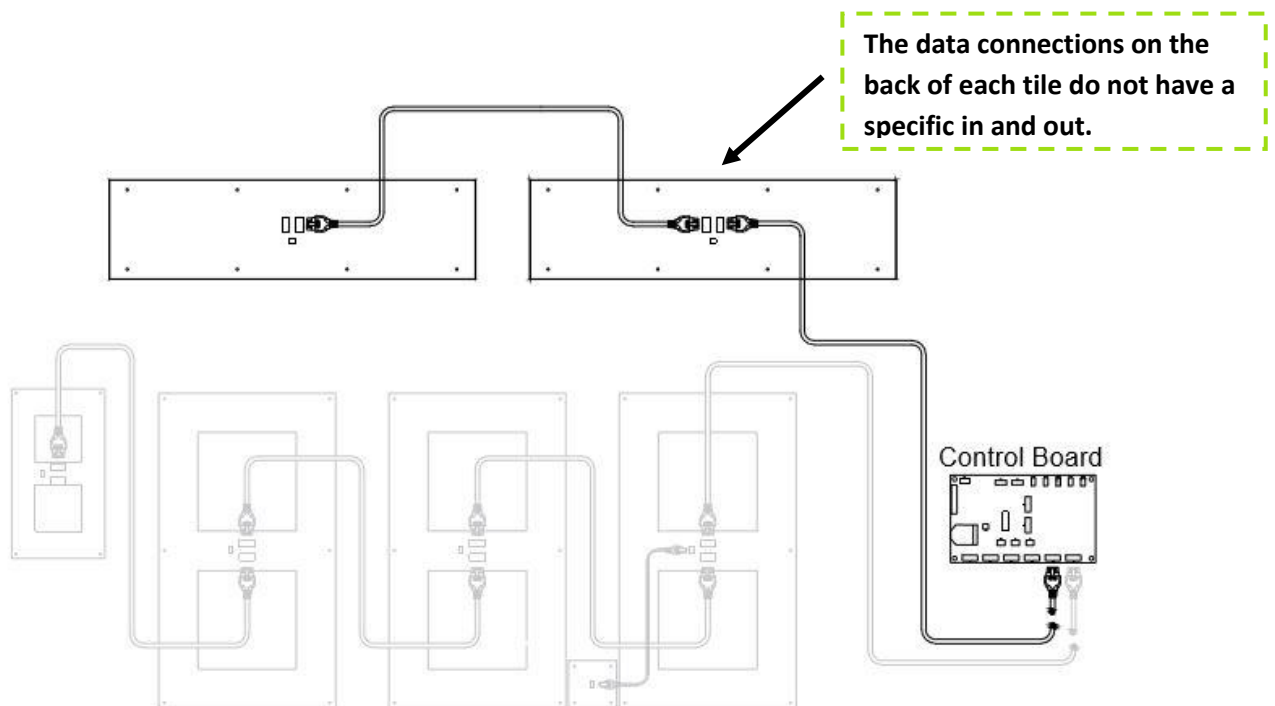

# Section 6: Connections

## 2x2 Default Display Wiring

- a) Use the long (10') digit cable to connect the Control Board to the first LED tile.
- b) Use the short (3') digit cables to connect between LED tiles.

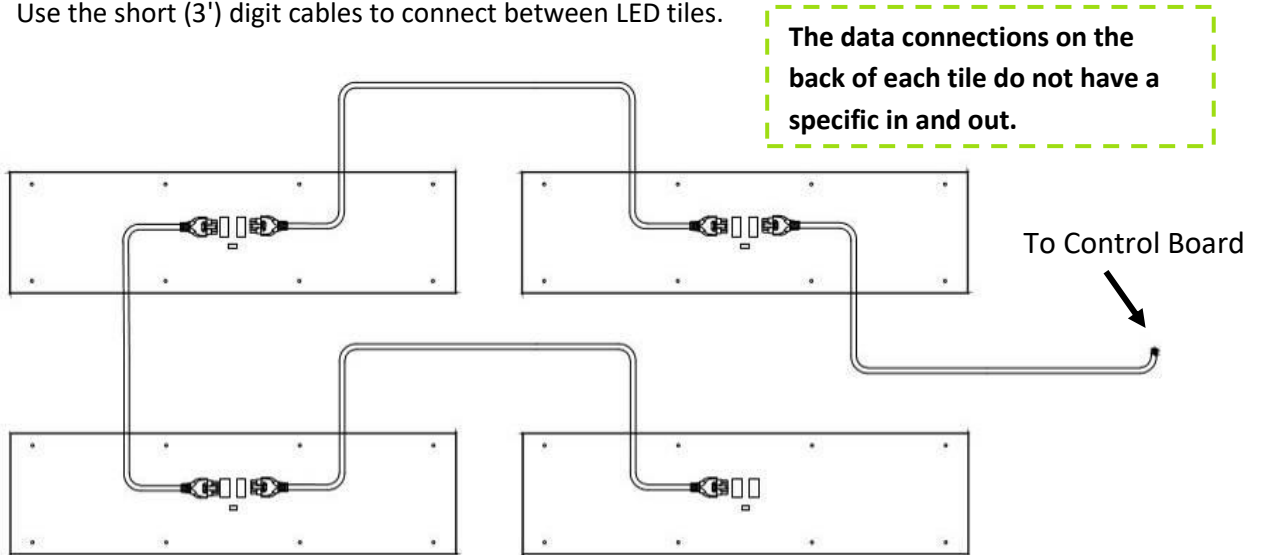

## 6.10 Completed Installation Drawing

After installation is complete a factory reset using dipswitch 1 on the controller must be performed.

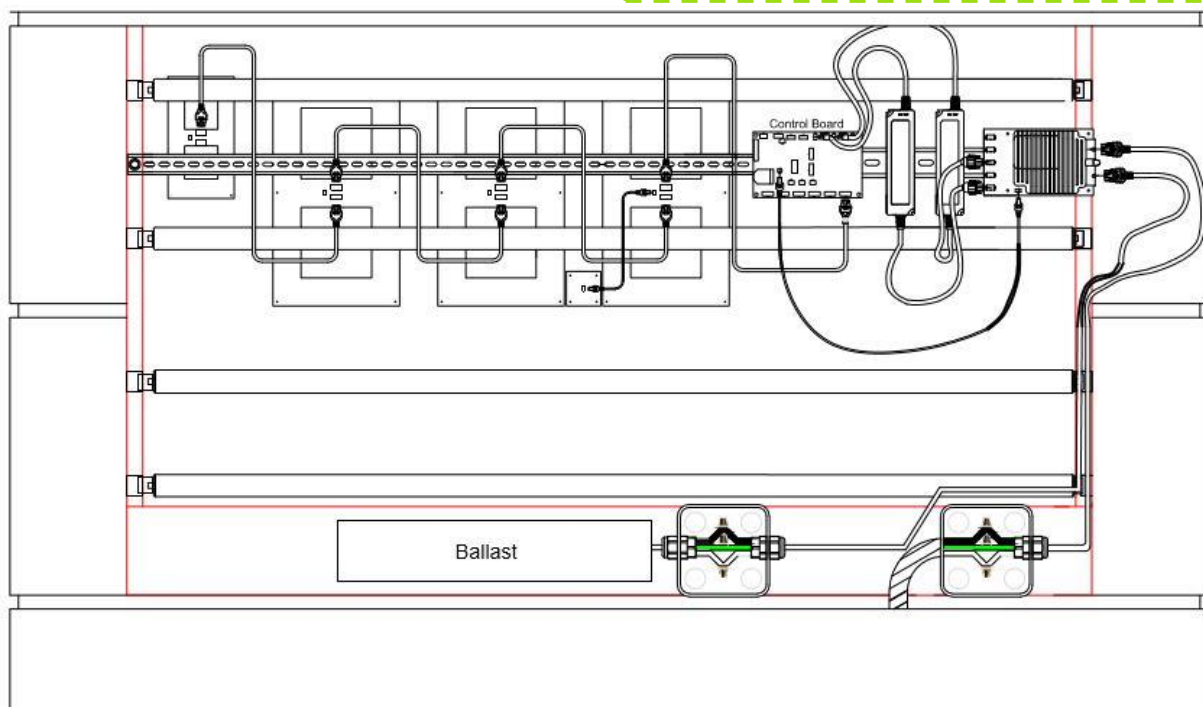

# Section 7: Radio Installation

## 7.1 Radio Guidelines for Best Performance

- The antenna on each radio must be vertical (up or down).
- The antenna at the sign must be mounted outside of the sign. If the antenna is mounted on the face of the sign it should be on the side facing the store.
- Signal strength for all signs can be viewed on the PricePad after setup.
- The PricePad ideally should have 3 or 4 bars of signal strength but will work with only 1 bar.
  - It may take longer to update prices and settings with low signal strength.
- If the signal strength is low, place the PricePad near a window that faces toward the sign with a clear line of sight.
- If a sufficient signal cannot be obtained by moving the PricePad in the store. An optional 20ft antenna cable can be ordered to mount the antenna on the exterior of the store.

*Antenna / Radio mounted, with line of sight, no obstructions.*

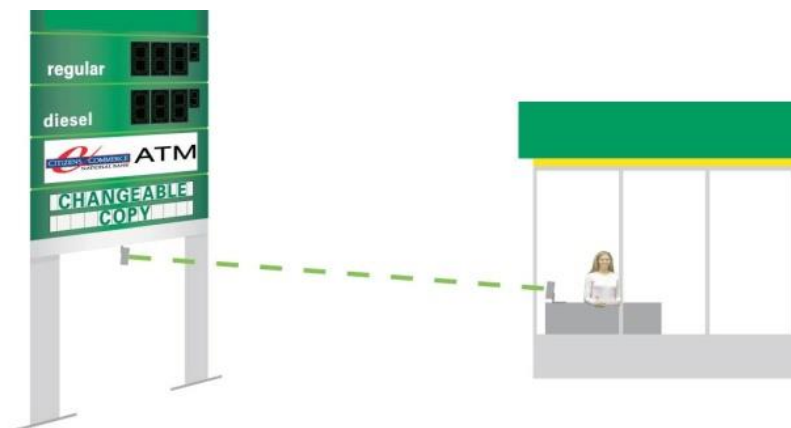

# Section 8: Factory Reset / Switch Settings

## 8.1 When to Perform a Factory Reset

- If digits are replaced.
- If a master controller is replaced.
- If digits are added.
- If digit cables are swapped between output jacks on the controller.

## 8.2 Factory Reset

A factory reset restores all installer settings to factory defaults. The only thing that is not affected is the binding of the Economy Remote and the user password, clock, timers, light mode, and light level. There are two ways to perform a factory reset:

1. Turn **dipswitch 1** on the master Control Board (*if there are multiple controllers in the sign*) to the **ON** position and **all other** switches to the **off** position.

**Dipswitch 1 MUST be turned off after the reset is complete.**

-or-

2. Use the Economy remote by entering the installer menu 7419138635. Select the reset option by pressing **↑** then **0** the sign will display **rESt**. Enter the reset code **90152953** then **OK**.

When the factory reset starts, all digits will display "**8**" for a few seconds. When the factory reset is complete the sign will display "**1119**" for the first product "**2229**" for the second product, and so on to the max number of products.

**Note:** Any changes made in the installer menu (*e.g. product mapping*) are reset when a factory reset is performed.

## 8.3 Digit Test Mode

The sign can indicate which digits were successfully addressed. This is useful for finding the location of digit cables with loose connections. In this mode the digits display their digit address number one at a time on a per channel basis. All other digits will display an **\_** (underscore). The digit address numbers should be sequential based on wiring of the digits. The digit connected to the controller board will be number 1.

There are 2 ways to enter addressed digit display mode.









1. Turn **dipswitch 3** on the master Control Board (*if there are multiple controllers in the sign*) to the **ON** position and **all other** switches to the **off** position.

**Dipswitch 3 MUST be turned off to exit addressed digit display mode.**

-or-

2. Use the Economy remote by entering the installer menu. From the installer menu go to the info menu by pressing **↑** then **4** the sign will display **inFd**. With the sign displaying **inFd** press **↑** then **3** to enter addressed digit display mode. To exit this mode press **OK**.

## 8.4 Dipswitch Functions

	∞	Sign Number Switch 3
	∞	Sign Number Switch 2
	∞	Sign Number Switch 1
	∞	Slave Address Switch 2
	∞	Slave Address Switch 1
	∞	Digit Test Mode
	∞	Power Supply Test
	∞	Factory Reset

# Section 9: Multiple Control Boards

## 9.1 When to use multiple Control Boards

- If the digits require more power than one Control Board can provide.
- If there are insufficient digit output channels to connect all of the digits.
- If multiple faces are physically separated such that Digit Cables cannot reach (ex. pump topper).

## 9.2 Control Board Switch Settings

The slave Control Board addresses must be set with switch 4 and switch 5. A maximum of 3 slave Control Boards can be connected to one master Control Board.

	Switch 4	Switch 5
Master Control Board	OFF	OFF
Slave Control Board 1	ON	OFF
Slave Control Board 2	OFF	ON
Slave Control Board 3	ON	ON

**Note:** All Control Boards connected together MUST have different addresses.

## 9.3 Connections Between Control Boards

Slave Control Boards are chained together with Controller Link cables.

- All Control Boards must be connected.
- Controller Link cables shall be daisy chained from master to slave, then slave to slave as needed.
- After all Control Boards are fully connected including digits, a factory reset must be performed. (see section 8.2)

### Example configuration with 4 Control Boards

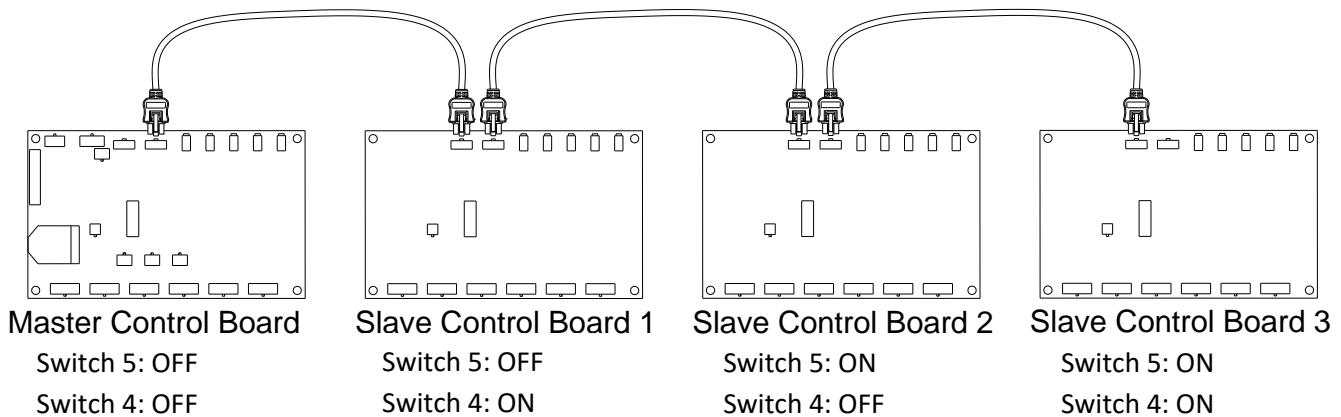

# Section 10: Sign Configuration

## 10.1 Number of faces

Number of faces (physical sides of a sign). Default value is 2 faces. The sign can be configured to have from 1 to 4 faces.

## 10.2 Digit Wiring

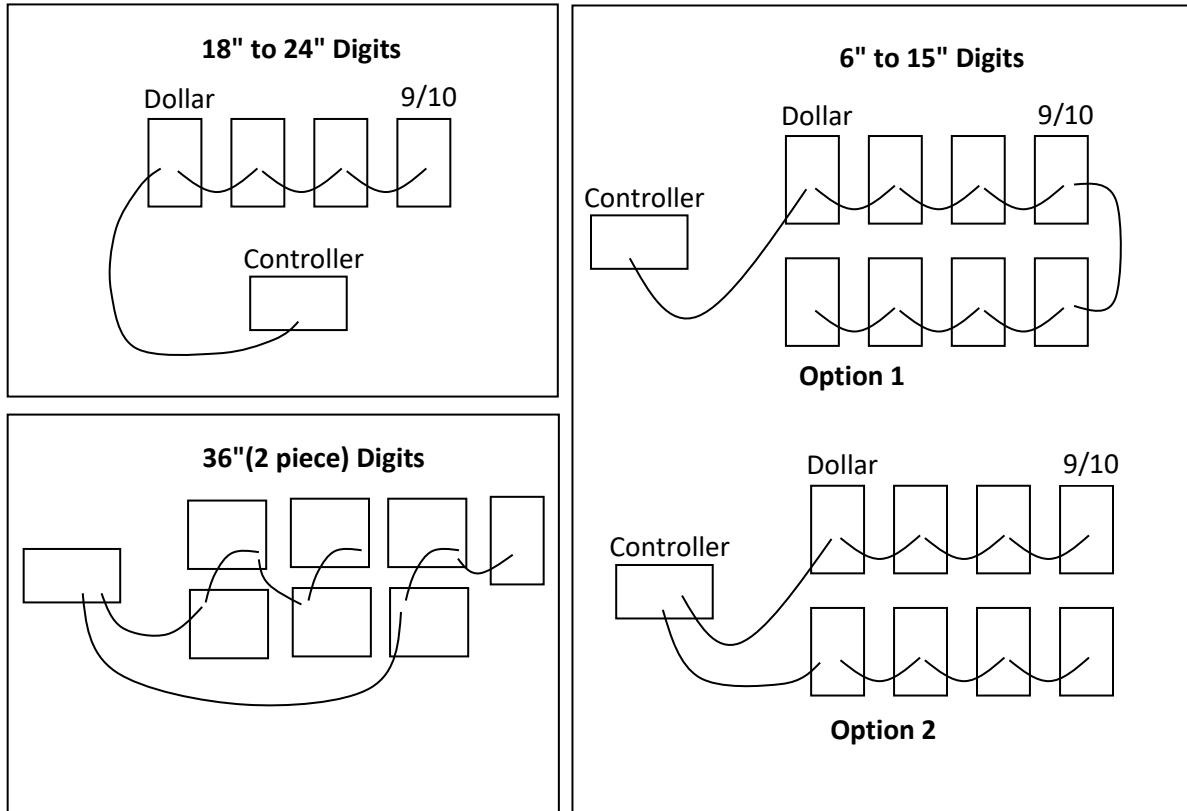

# Section 10: Sign Configuration

## 10.3 Product Mapping

Product mapping is used to reassign lines on the sign to products. A line consists of 4 digits (3 digits and 9/10) that can display a price. A product contains one line for every face on the sign. Example: a 2-face sign would have 2 lines assigned to each product. Unleaded, Premium, Diesel would be considered products.

If the included sign specific wiring diagram is followed and the sign has the same number of lines on each face no additional configuration is needed.

### Default Product Mapping Rules (Order digit cables are connected to controller board(s))

- Max lines that can be connected per channel.

Digit sizes	Max Lines Per Channel (4 digits per line)	Max Lines Per Channel (5 digits per line)
6"	3	2
9" - 15"	2	1
18" - 24"	1	1

Rules for connecting digit cables to controller board(s):

(A complete wiring diagram specific to each sign is included)

- a. Line 1 is connected to the bottom right connector (Channel 1) on the master controller. (If there is only one controller in the sign, it is the master controller).
- b. If line 2 has a direct connection back to controller, it will be connected to Channel 2.

If multiple lines are connected to Channel 1, the next channel will be used for the next line number (see example below).

Connecting the digits to the controller in a way not recognized by the above rules is possible, but will require an additional configuration step. (Product Mapping).

# Section 10: Sign Configuration

**Example Configuration:** Sign with 3 Faces, 2 Products Per Face, 12" digits

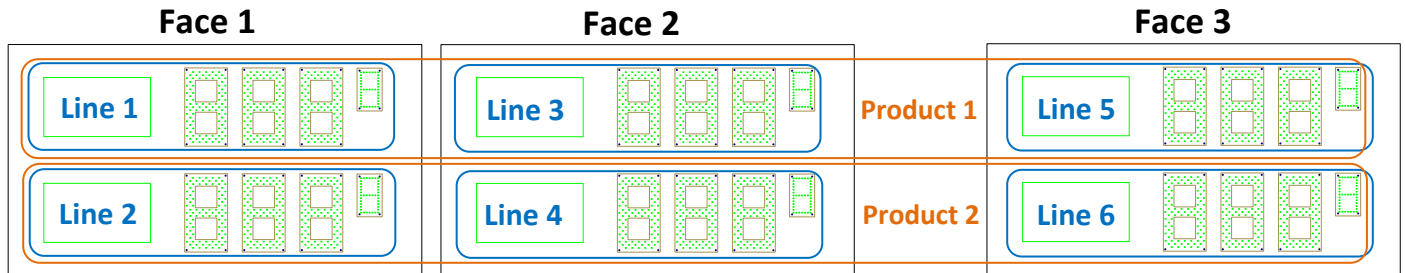

## Controller

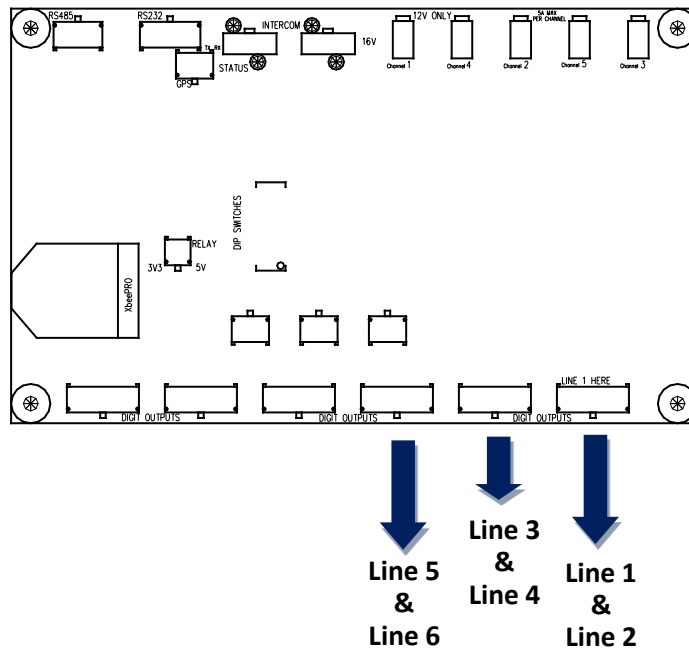

**Note:** A sign specific wiring diagram is included for each sign. The following are just examples configurations and not specific to each sign.

# Section 10: Sign Configuration

**Example Configuration:** Sign with 2 Faces, 3 Products Per Face, 12" digits

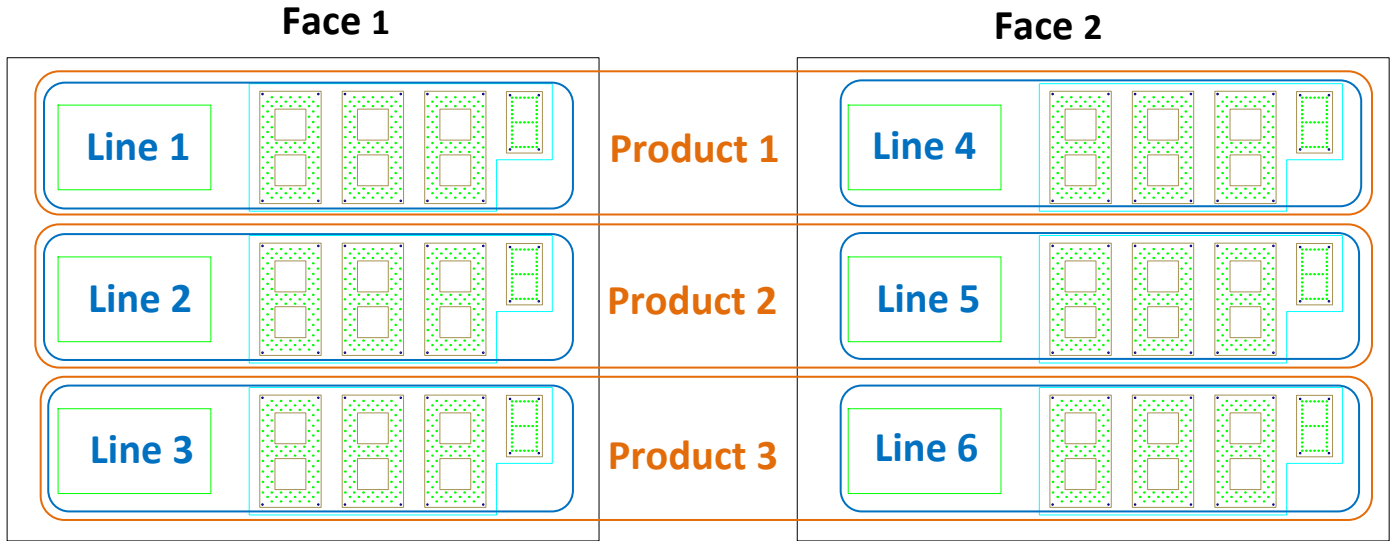

## Controller

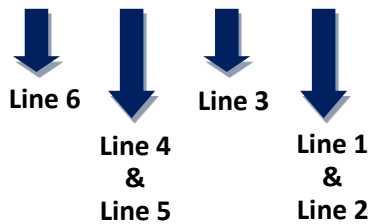
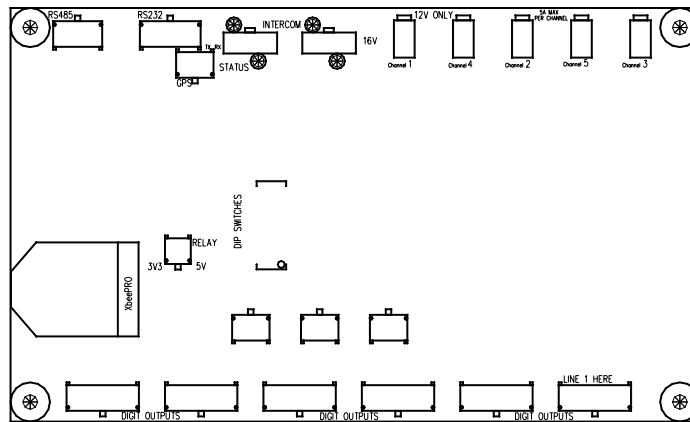

# Section 10: Sign Configuration

**Example Configuration:** Sign with 2 Faces, 3 Products Per Face, 24" digits

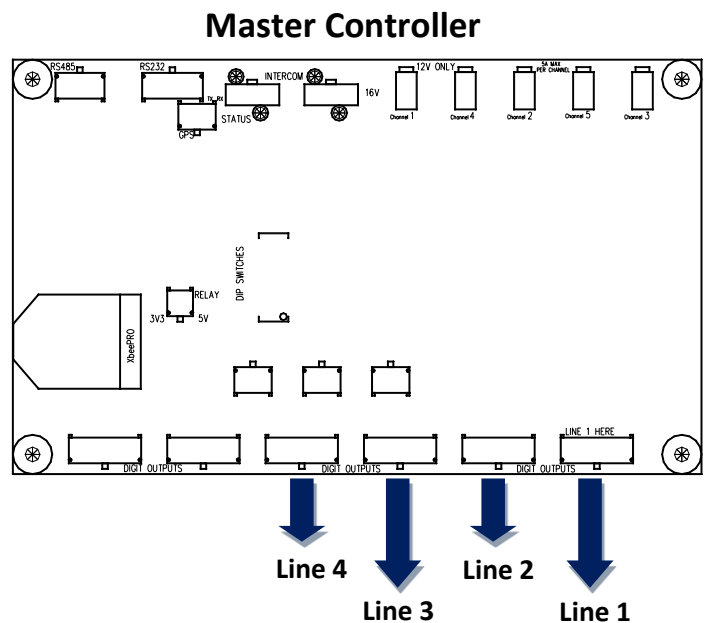
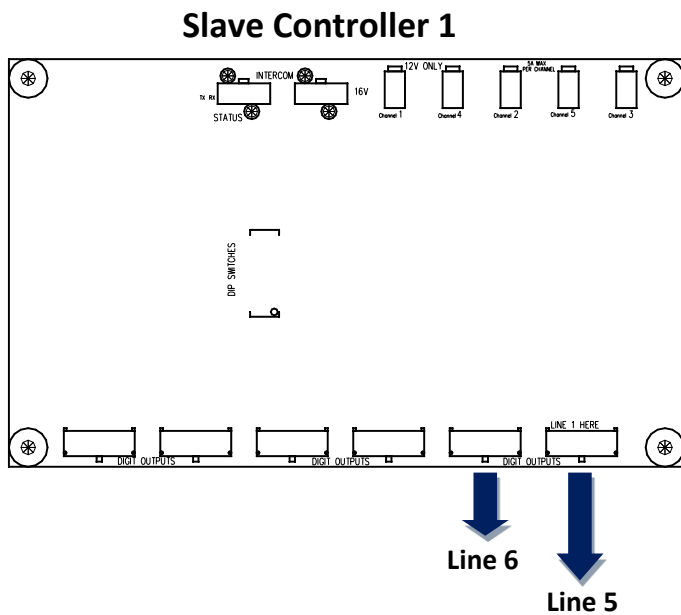
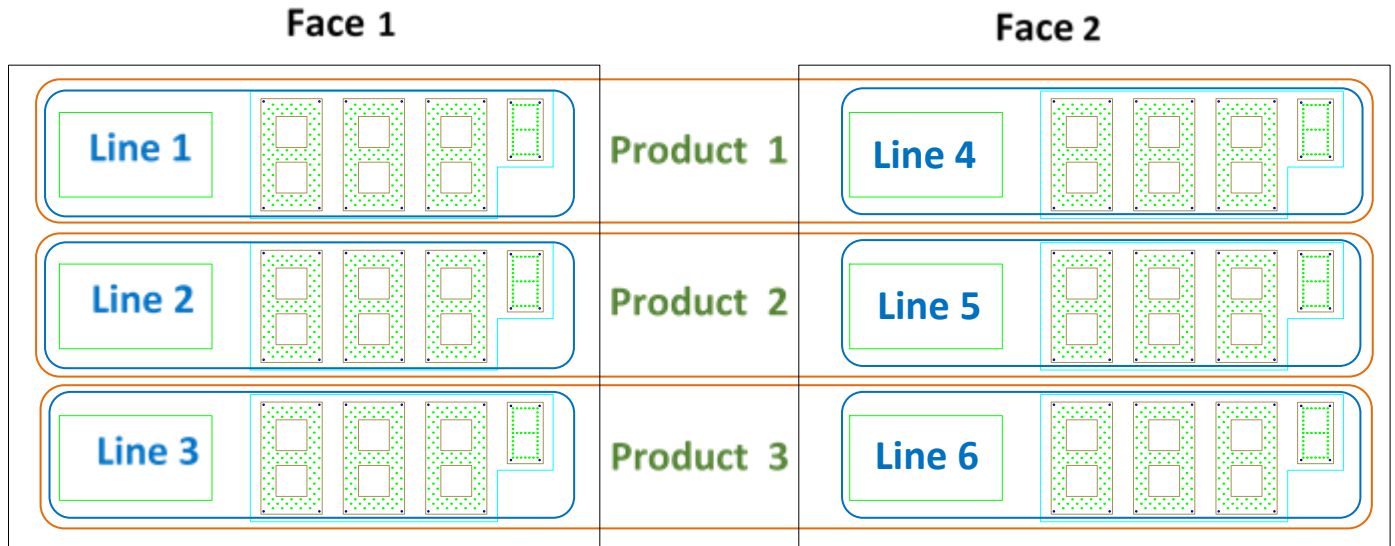

## Section 11: Economy Remote Binding

To avoid interference between adjacent signs, each remote is equipped with a unique ID and must be bound to the sign before it can be used.

- Remotes shipping with new signs will already be bound to the sign.
- Every sign should have its own remote. The same remote should not be used with multiple signs.

### Steps

1. Power cycle (*turn the sign off and then back on*) with either the breaker or switch at the sign.
2. Press and hold buttons ⑥ and ⑨ at the same time on the remote that is being bound to the sign. The entire sign will then flash. *If the sign does not flash ensure the remote is turned on, the antenna is extended, and the battery is good.*
3. Once the sign has stopped flashing, power cycle the sign again.
4. Press and hold buttons ⑥ and ⑨ at the same time on the remote that is being bound to the sign. The sign will flash bind. After a few seconds, bind will stop flashing and the sign will go into normal operation bound to the new remote.

**Note:** When a new remote is bound to a sign, the old remote is automatically unbound. Only one remote can be bound to a sign at a time.

# Section 12: Economy Remote User Menu

## User Menu Summary

The following tasks can be accomplished from the USER menu:

- Update prices
- Set the clock on the sign
- Set a timer that can turn the sign off at night and back on in the morning
- Set a timer that controls the sign brightness level during the day and night
- Set the day-time brightness level
- Set the night-time brightness level
- Temporarily override the timers
- Blank out product, if desired

### Enter User Menu (USER)

When the sign is displaying prices or blanked out:

- Type the 4-digit user code to enter **USER** menu.
- The User Code is unique for each site and is written on Economy Remote sticker.

### Exit User Menu

When sign displays **USER**:

- Press **OK OK** to exit to price display or wait for the **USER** mode timeout.

### Set Price

- Enter **USER** Menu.
- Press **↑** then **1** to enter the Set Price sub menu:
  - All products accept the selected one are shut off.
- The selected digit will flash.
- Update the price by pressing buttons **0** - **9** on the remote.
  - When a number (0 - 9) is pressed, the next digit is selected.
  - After the last digit in the price is updated, the first is selected again.
- Press **OK** to save current price and move on to the next price.
  - After the last price has been updated and saved, the sign returns to the **USER** menu.

# Section 12: Economy Remote User Menu

## Set Counters

- **Note:** Product must be setup as a counter for these options to be present. The counter options replace the standard price update options.
- Press **↑** then **1** to enter the Set Price sub menu.
  - All products except the selected one are shut off.
- The user setup depends on which one of three modes the counter is in.
  - **Mode 1** set initial count.
    - The initial count is displayed.
    - Update the count if needed and press **OK** to move to the next product.
  - **Mode 2** set initial time and date.
    - The sign displays *hE*, then the initial time in 24-hour format HHMM.
    - The selected digit will flash.
    - Update the time by pressing buttons **0** - **9** on the remote.
      - When a number (0 - 9) is pressed, the next digit is selected.
      - After the last digit in the time is updated, the first is selected again.
    - Press **OK** to save initial time and move on to initial date.
      - Sign displays *rd*, then the date can be entered with the format MMDD.
      - Example: Feb. 24 would be entered as 0224 (only valid dates are accepted).
    - Press **OK** to save initial date and move on to initial year.
      - Sign displays *ry*, then the year can be entered with the format YY starting at 2000.
      - The max year that can be entered is 2099.
    - Press **OK** to save and move to the next product or back to the *USER* menu if the last product has been updated.
  - **Mode 3** set initial count plus initial time and date.
    - Sign displays *CntE*, then the initial count.
    - Update the initial count if needed and press **OK**.
    - The Sign displays *hE*, then the initial time. Set the initial time in 24 hour format HHMM and press **OK**.
    - Sign displays *rd*, then the initial date. Set the initial date with the format MMDD and press **OK**.
    - Sign displays *ry*, then the initial year. Set the initial year with the format YY starting at 2000.
    - Press **OK** to move to the next product or back to the *USER* menu if the last product has been updated.

# Section 12: Economy Remote User Menu

## Enable / Disable Products

Products (ex. Unleaded, Premium, Diesel) can be enabled (operate normally) and disabled (blank).

- Enter **USER** Menu.
- Press **↑** then **2** to enter the Enable / Disable Products sub menu.
  - All products will display **YES** (product is enabled) or **no** (product is disabled)
- The selected product will flash.
- Press **0** to change between **YES** and **no**, if desired.
- Press **OK** to save this setting and move to next product.
  - After the last product has been saved, the sign returns to **USER** menu.

## Set Clock

Sets the signs internal clock which is used for the timers.

- Enter **USER** Menu.
- Press **↑** then **4** to enter the Set Clock sub menu.
  - The sign displays **CL**, then the current time in 24 hour format HHMM

12 Hour	24 Hour	12 Hour	24 Hour
12:00 AM	00:00	12:00 PM	12:00
1:00 AM	01:00	1:00 PM	13:00
2:00 AM	02:00	2:00 PM	14:00
3:00 AM	03:00	3:00 PM	15:00
4:00 AM	04:00	4:00 PM	16:00
5:00 AM	05:00	5:00 PM	17:00
6:00 AM	06:00	6:00 PM	18:00
7:00 AM	07:00	7:00 PM	19:00
8:00 AM	08:00	8:00 PM	20:00
9:00 AM	09:00	9:00 PM	21:00
10:00 AM	10:00	10:00 PM	22:00
11:00 AM	11:00	11:00 PM	23:00

- The selected digit will flash.
- Update the time by pressing buttons **0** - **9** on the remote.
  - When a number (0 - 9) is pressed, the next digit is selected.
  - After the last digit in the time is updated, the first is selected again.
- Press **OK** to save time and move on to date.
  - Sign displays **CD**, then the date can be entered with the format MMDD.
  - Example: Feb. 24 would be entered as 0224 (only valid dates are accepted).
- Press **OK** to save date and move on to year.
  - Sign displays **CY**, then the year can be entered with the format YY starting at 2000.
  - The max year that can be entered is 2099.
- Press **OK** to save year and return to the **USER** menu.

# Section 12: Economy Remote User Menu

## Sign On / Off Timer

Used to turn the sign off at night and on in the morning. To keep the sign on 24 hours a day set both the **on** and **OFF** times to 0.

- Enter **USER** Menu.
- Press **↑** then **5** to enter the Sign On / Off Timer sub menu.
  - Sign displays **on** for a short period, then the time when the sign will turn on in 24-hour format HHMM.
- The selected digit will flash.
- Update the time by pressing buttons **0** - **9** on the remote:
  - When a number (0 - 9) is pressed, the next digit is selected.
  - After the last digit in the time is updated, the first is selected again.
- Press **OK** to save the time.
  - Sign displays **OFF** for a short period, then the time when the sign will turn off in 24-hour format HHMM.
- Press **OK** to save the time and return to the **USER** menu.

## Sign Bright Timer

Controls when the sign changes between day and night light levels. If the sign should not change light levels, set both **brH** and **brLo** to 0, and use Night Light Level to control the sign's brightness.

- Enter **USER** Menu.
- Press **↑** then **6** to enter the Sign Bright Timer sub menu.
  - Sign display **brH** for a short period, then the time when the sign switches from Night Light Level to Day Light Level in 24-hour format HHMM.
- The selected digit will flash.
- Update the time by pressing buttons **0** - **9** on the remote:
  - When a number (0 - 9) is pressed, the next digit is selected.
  - After the last digit in the time is updated, the first is selected again.
- Press **OK** to save the time.
  - Sign display **brLo** for a short period, then the time when the sign switches from Day Light Level to Night Light Level in 24-hour format HHMM.
- Press **OK** to save the time and return to the **USER** menu.

# Section 12: Economy Remote User Menu

## Manual Light Level

Used to override the current light level set by the timers and turns the sign lights on and off. These changes do not take effect until sign exits the *USER* menu and is displaying prices.

- Enter *USER* Menu.
- Press **↑** then **7** to enter the Manual Light Level sub menu.
- Press **0** to change between *AUTO*, *PHOT*, *DAY*, *NITE*, and *OFF*:
  - *AUTO*- Sets light level according to the timers and uses timers to turn sign on and off.
  - *PHOT* - Sets light level according to photo cell and uses timers to turn sign on and off.  
(*PHOT* option present in controller software 03 or greater)
  - *DAY*- Sets light level day and turns the sign lights off (timers will have no effect).
  - *NITE*- Sets light level to night and turns the sign lights on (timers will have no effect).
  - *OFF*- Blanks out sign and turns sign lights off (Sign is not powered off, typing user code will still take the sign to the *USER* menu).
- Press **OK** to save the Manual Light Level and return to *USER* menu.
  - Manual Light Levels do not take effect until the sign returns to displaying prices.

## Day Light Level

Day Light Level is the sign brightness when the sign is in day mode.

- Enter *USER* Menu.
- Press **↑** then **8** to enter the Day Light Level sub menu.
- The selected digit will flash.
- Update the light level by pressing buttons **0** - **9** on the remote:
  - Valid light levels are between 00 - 99 (00 - min light level, 99 - max light level)
  - When a number (0 - 9) is pressed the next digit is selected
  - After the last digit in the light level is updated, the first is selected again
- Press **OK** to save light level and return to *USER* menu.

## Night Light Level

Night Light Level is the sign brightness when the sign is in night mode.

- Enter *USER* Menu.
- Press **↑** then **9** to enter the Night Light Level sub menu.
- The selected digit will flash.
- Update the light level by pressing buttons **0** - **9** on the remote:
  - Valid light levels are between 00 - 99 (00 = min light level, 99 = max light level).
  - When a number (0 - 9) is pressed the next digit is selected.
  - After the last digit in the light level is updated, the first is selected again.
- Press **OK** to save light level and return to *USER* menu.

**Note:** Night and Day light levels do not affect the light level of the user and installer menu. To see the effect of the light level change, the operator must exit the user menu.

# Section 13: Economy Remote Installer Menu

## Installer Summary

The following tasks can be accomplished from the **INSTALLER** menu:

- Set the number of faces on the sign.
- Set the wiring direction of each digit channel.
- Assign lines to products.
- Display software versions for digits and controllers.
- Change the User Code.
- Set the current time zone (important if a GPS is in use).
- Setup daylight savings time.
- Configure 9/10 digit as fixed or changeable, and if fixed, set the fixed value.
- Readdress all digits on sign.
- Reset the sign to factory conditions.

### Enter Installer Menu ( **INSt** )

When the sign is displaying prices or blanked out:

- Type the 10-digit installer code to enter **INSt** menu.
- Installer code: 74191 38635.

### Exit Installer Menu

When sign is displaying **INSt**:

- Press **OK OK** to exit to price display or wait for the **INSt** mode timeout.

### Set Number of Faces

- Enter **INSt** Menu.
- Press **↑** then **1** to enter the Set Number of Faces sub menu:
  - All products except one are shut off.
- Update the number of faces by pressing buttons **1** - **4** on the remote.
- Press **OK** to save number of faces.
  - After saving, the sign returns to the **INSt** menu.

# Section 13: Economy Remote Installer Menu

## Change Wire Direction

A sign specific wiring diagram will be shipped with the sign. When possible use this diagram for manufacturers recommended installation. The wire direction only needs to be changed if the default was not used. By default, the controller is connected to the dollar digit of the first line.

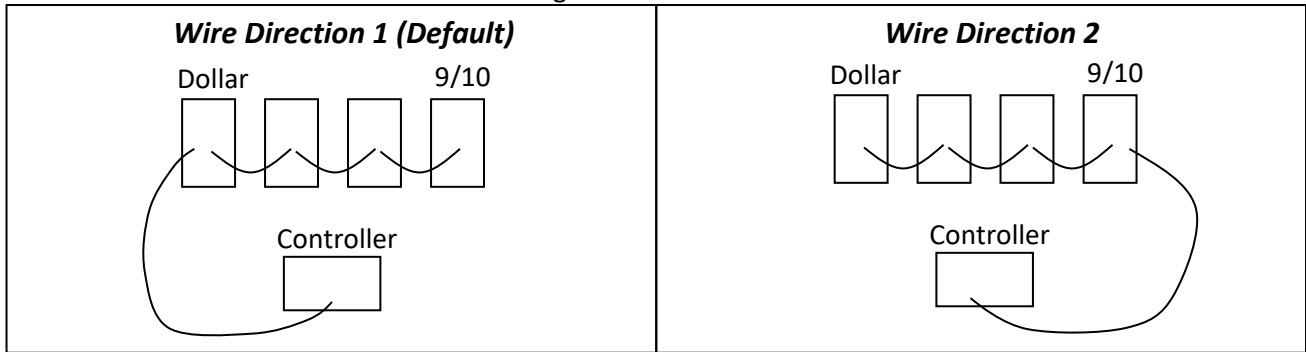

If two or more lines are connected to a channel there are 4 options.

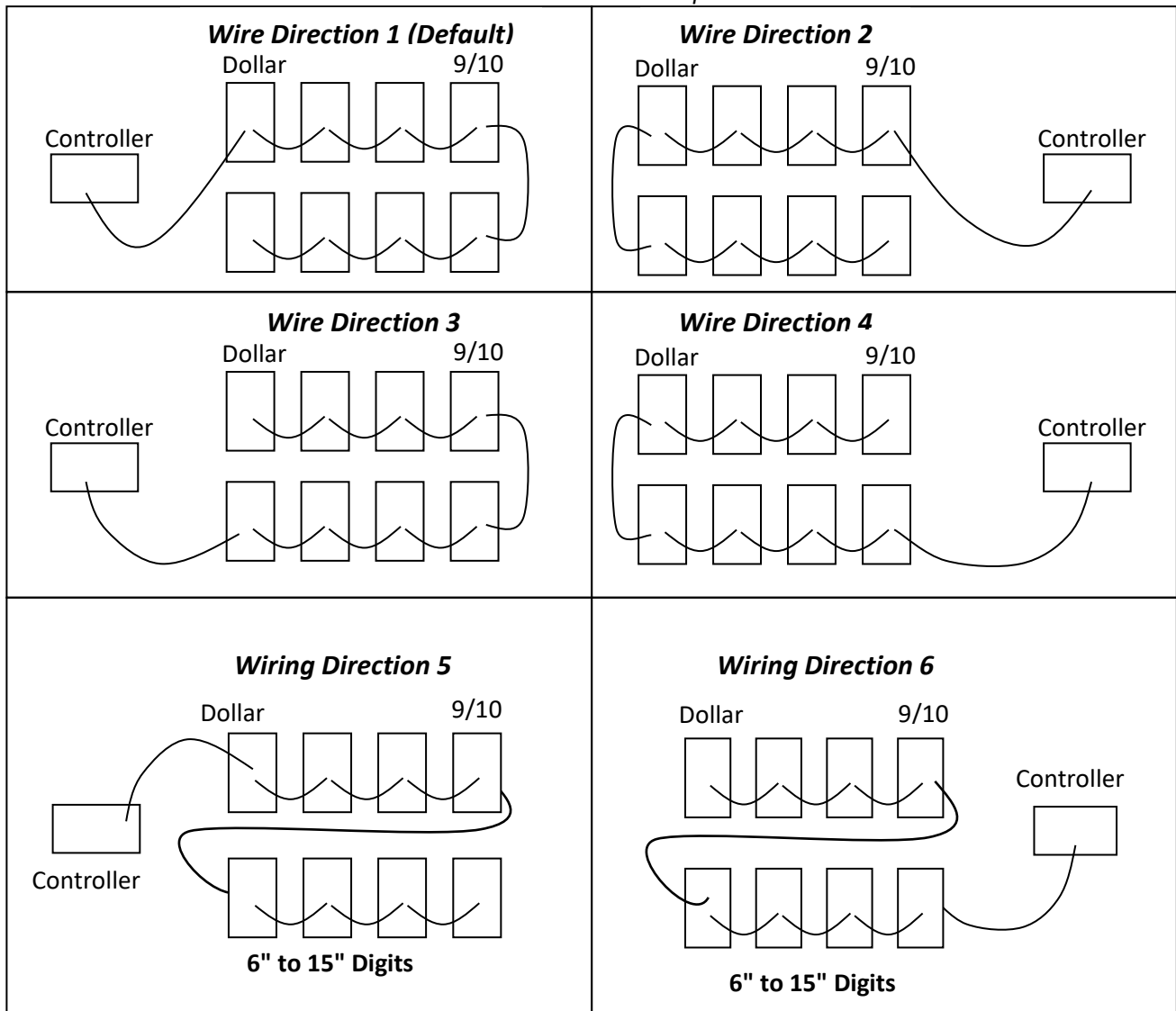

# Section 13: Economy Remote Installer Menu

When the correct wire direction is selected the first line should display **123**. If a second line is connected to the channel, it should display **456**. If a third line is connected to the channel, it should display **789**.

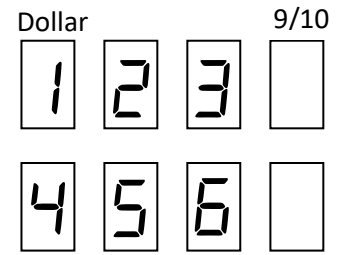

Example of Correct Display

- Enter **inSt** Menu.
- Press **↑** then **2** to enter the Change Wire Direction sub menu.
  - The digits attached to one channel will display number counting up as stated above.
- Pressing the buttons **1** through **6** on the remote will select the corresponding wire direction.
- When satisfied with the wire direction, press **OK** to save and move on the next channel.
  - After the channel has been saved, the sign returns to **inSt** menu.

## Product Mapping

Used to assign lines on the sign to products. A line consists of 4 digits (3 digits and 9/10) that can display a price. A product contains one line for every face on the sign. Example: a 2-face sign would have 2 lines assigned to each product. Unloaded, Premium, Diesel would be considered products.

### Rules for assigning product numbers

- No product numbers can be skipped:
  - Example: The lines on a 4-product sign must be assigned to **01, 02, 03, and 04**.
- No product numbers can be used more times than the number of faces on the sign.
  - Example: A two face sign cannot have more than 2 lines assigned to one product.

### How to assign product numbers

- Enter **inSt** Menu.
- Press **↑** then **3** to enter Product Mapping.
  - One line on sign will display **01** (it could be on any face).
  - This number is the product number the line is assigned to (Max number of products is 12).
- Update the product number if needed by typing a number from **01** to **12**.
  - The rules above must be followed to changes line to products mapping:
    - If the rules are not followed the mapping will not be saved.
- Press **OK** to move on to the next line.
  - Update remaining lines.
- After the last line has been updated.
  - The sign returns to the **inSt** menu if the update was successful.
  - The sign returns to the first line if the assignment rules were not followed and nothing is saved.

# Section 13: Economy Remote Installer Menu

## Sign Information ( *inFo* )

This mode will display the version numbers for all the digits and controllers in the sign.

- Enter *inSt* Menu.
- Press **↑** then **4** to enter the sign information sub menu:
  - Sign will display *inFo*:
    - Press **OK** to return to *inFo* menu from any of the sub menus.
  - Press **↑** then **1** to display digit software versions.
  - Press **↑** then **2** to display controller software versions:
    - Sign displays **C 1** for a short period then the software version of controller 1. Press **OK** to advance through slave controllers **C2** to **C4** if installed then back to the *inFo* menu.
  - Press **↑** then **3** to display **A** on digits that are properly addressed.
  - Press **↑** then **4** to display internal sign temperature (in deg. C).
    - Sign displays **EC 1** for a short period then clock temperature for controller 1. Press **OK** to advance to **EH 1** controller 1 heat sink temp. Continue pressing **OK** to advance through temperatures of slave controllers **EC2**, **EH2**, **EC3**, **EH3**, **EC4**, **EH4** if installed.
  - Press **↑** then **5** to display results from the last power supply test:
    - Sign displays **totA** for a short period then the total number of supplies tested.
    - Press **OK** to advance to **PASS** to display the number of supplies that passed.
    - Press **OK** to advance to **FAI L** which displays the number of supplies that failed.
  - Press **↑** then **6** to start a power supply test.
    - Test may take up to 1 min. to run. Sign will vary in brightness and display during test.
- If sign is displaying *inFo* press **OK** to return to *inSt* menu.

## Change User Code

It is recommended that the user keeps their default code for the highest level of security.

- Enter *inSt* Menu.
- Press **↑** then **5** to enter the Change User Code sub menu.
- The new User Code must be entered once with the remote followed by **OK**:
  - The code must contain exactly 4 numbers from 1111 to 9999 it cannot contain 0's.
  - Sign displays **Code** and flashes every time a button is pressed.
  - If the code is the incorrect length the sign will display **FA iL**.
- The new User Code must be entered a second time followed by **OK**:
  - The first and second entry must match or the sign will display **FA iL**.
  - If the User Code was successfully changed the sign will display **PASS**.
- When the sign says **PASS** or **FA iL** press **OK** to return to *inSt* menu.

# Section 13: Economy Remote Installer Menu

## Set Time Zone

If a GPS is attached to the sign, the time zone MUST BE set.

### USA Time Zone Values

Eastern Time : - 5      Central Time : - 6      Mountain Time : - 7      Pacific Time : - 8

- Enter **INSt** Menu.
- Press **↑** then **6** to enter the Set Time Zone sub menu.
- The sign displays the sign (positive or negative) of time zone offset Press **0** to change between **Pos** and **NEG**.
- Press **OK** to save sign (positive or negative) and move to value:
  - Enter value from **00** to **12** corresponding to time zone offset.
  - Default is 0 if time zone function is not used (No GPS).
- Press **OK** to save time zone value and return to **INSt** menu.

## Display Settings (**d iSP**) (must have controller software version 10 or greater)

- Enter **INSt** Menu.
- Press **↑** then **7** to enter **d iSP** sub menu. The sign will display **d iSP**.

### Set number of Payment Methods

A payment method can be either a price or other display type. Each product can display between 1 to 8 payment methods. This is done by toggling through them at a rate determined by the payment display time.

- Press **↑** then **1** to enter the set number of payment methods sub menu.
- The first product will display its current number of payment methods.
- Update the number of payment methods if needed.
- Press **OK** to advance to the next product.
- Continue updating the remaining products.
- After the last product has been updated press **OK** to return to the **d iSP** menu.

### Payment Display Time

If a product has multiple payment methods the sign will toggle between them a rate set by payment method display time.

- Press **↑** then **2** to enter the set the payment method display time.
- Enter the desired payment display time. The payment display time base is 100ms. Valid settings are from 10 (1 second) to 999 (99.9 seconds).
- Press **OK** to return to the **d iSP** menu.

### Display Text Selection

The type of payment methods is selected by toggling through the menu of options.

- Press **↑** then **3** to enter the set the text options to be displayed.
- Press **0** to toggle through the options. (Default options include; Cash, Credit, Debit, Card, Special, Fleet, Diesel, and Plus, Member).
- Press **OK** to assign the display text and repeat for each payment assigned.
- Press **OK** to return to the **d iSP** menu.

## Section 13: Economy Remote Installer Menu

### *Display Text Editor*

The text selection can be set to different fonts, sizes, and justifications for each text displayed.

- Press **↑** then **4** to access the menu to alter the display text.
- Press **1** to cycle the justification setting; this will change where the text appears on the text display.
- Press **3** to cycle the font size.
- The active character will be flashing, to navigate and adjust characters:
  - Press **6** to move to the next character (right) or press **4** to move to the previous character (left).
  - The active character can be reset to a space by pressing **5**.
  - The active character can be changed by pressing **2** or **8**.
  - Press **OK** to continue to the next display assigned.
  - The text justification can be changed by pressing **1**. There are 9 justifications that will be toggled between. (Top left, center left, bottom left, top center, center center, bottom center, right top, right center, right bottom)
  - The text font and size can be changed by pressing the **3**. There are 5 options that can be toggled between. (single high narrow, single high regular, single high wide, double high narrow, double high wide)
- Press **OK** to return to the **d iSP** menu.

### *Display Number*

There can be up to 12 separate text displays. Each display is assigned a display number. Text displays sharing a number will display the same messages. To assign numbers to the text displays:

- Press **↑** then **5** to access the menu to update display numbers for each tile.
- Each tile will show its current display number. Valid display number range from 1 to 12. There **cannot** be gaps in the numbering. For example, if a display number is set to 4 there must also be displays assigned numbers 1, 2, and 3.
- Set the numbers and Press **OK** to return to the **d iSP** menu.

# Section 13: Economy Remote Installer Menu

## Display Position (X,Y) Coordinates

The text displays can be configured to display messages across several LED tiles up to 2 x 4; examples are shown below:

Configuration Options											
<table border="1"><tr><td>1,1</td></tr></table> 1 x 1				1,1							
1,1											
<table border="1"><tr><td>1,1</td><td>2,1</td></tr></table> 1 x 2				1,1	2,1						
1,1	2,1										
<table border="1"><tr><td>1,1</td><td>2,1</td><td>3,1</td></tr></table> 1 x 3				1,1	2,1	3,1					
1,1	2,1	3,1									
<table border="1"><tr><td>1,1</td><td>2,1</td></tr><tr><td>1,2</td><td>2,2</td></tr></table> 2 x 2				1,1	2,1	1,2	2,2				
1,1	2,1										
1,2	2,2										
<table border="1"><tr><td>1,1</td><td>2,1</td><td>3,1</td></tr><tr><td>1,2</td><td>2,2</td><td>3,2</td></tr></table> 2 x 3				1,1	2,1	3,1	1,2	2,2	3,2		
1,1	2,1	3,1									
1,2	2,2	3,2									
<table border="1"><tr><td>1,1</td><td>2,1</td><td>3,1</td><td>4,1</td></tr><tr><td>1,2</td><td>2,2</td><td>3,2</td><td>4,2</td></tr></table> 2 x 4				1,1	2,1	3,1	4,1	1,2	2,2	3,2	4,2
1,1	2,1	3,1	4,1								
1,2	2,2	3,2	4,2								

In order to configuration multiple LED tiles as a single display the display number assigned to each tile **MUST** match. The tile number can be checked and updated with the Display Number feature.

- Press **↑** then **6** to access the display position menu.
- For the desired configuration enter the coordinates as shown in the Configuration Options diagram.
- Press **OK** to confirm the tile coordinates and to move the selection to the next tile.
- After all the tiles are properly mapped, press **OK** to return to the **dISP** menu.

## Display Reset (controller V21 or greater)

After installing a text display or moving a text display to a different channel on the controller a factory reset then a text display reset must be performed. A text display reset, resets all setup done in the display menu back to factory defaults.

Steps:

- Press **↑** then **0** to enter the display reset sub menu.
- **LEr** will appear, enter **123** then press **OK** to confirm.

# Section 13: Economy Remote Installer Menu

## Advanced Options (PLUS) (must have controller software version 08 or greater)

- Enter **Inst** Menu.
- Press **↑** then **8** to enter **PLUS** sub menu. The sign will display **PLUS**.

### Configure 9/10 digit

The 9 in the 9/10 digit can be changed to any number (ex. 7/10). The digit has two modes: static or programmable. Static mode only allows the value to be changed in the installer menu. In programmable mode the value can only be changed in the user menu.

- Press **↑** then **1** to enter the Configure 9/10 Digit sub menu.
- The sign will display **StAtE** indicating the 9/10 is static (not changeable in user mode).
- Press **0** to change between **StAtE** (Static) and **PrO** (Programmable).
- Press **OK** to save the mode.
  - If the mode is saved as **StAtE** enter the desired 9/10 value (**0** to **9**) then press **OK** to save and exit to **PLUS** sub menu.
  - If the mode is saved as **PrO** sign will exit to **PLUS** sub menu.

### Light Sensor (Photocell) Relay Settings

These settings are used to adjust when the light sensor turns the relay (lamp out) on and off.

- Press **↑** then **2** to enter the light sensor Relay Settings sub menu:
  - Sign displays **LP** for a short period, then the light level percentage determined by the light sensor. 100 = Full brightness, 0 = Min brightness
- Press **OK** to move to relay light level threshold setting **Lt**:
  - The threshold is the light percentage detected by the light sensor where the relay will turn on and off. The default is **20** percent.
  - Update the threshold if the relay needs to turn on at a different ambient light level.
- Press **OK** to move to relay light level hysteresis setting **LH**:
  - The hysteresis value is the percent above and below the threshold setting the sensor must read to turn the relay on and off (This stops the relay output from oscillating between on and off). The default is **10** percent.
  - Increase the hysteresis slightly if relay oscillates on and off at dawn and dusk.
- Press **OK** to save and exit to **PLUS** sub menu.

### Light Sensor (Photocell) Min Max Settings

These settings change the minimum and maximum thresholds for light sensor readings.

- Press **↑** then **3** to enter the light sensor Min Max Settings sub menu:
  - Sign displays **Sr** for a short period, then the current light sensor reading
- Press **OK** to move to sensor low limit setting **SL**:
  - Sensor low limit is the sensor reading that will adjust the sign to min. light level
  - The default is **001**, update the threshold if desired.
- Press **OK** to move to sensor high limit setting **SH**:
  - Sensor high limit is the sensor reading that will adjust the sign to max light level
  - The default is **562**, update the threshold if desired.
- Press **OK** to save and exit to **PLUS** sub menu.

# Section 13: Economy Remote Installer Menu

## Advanced Options (PLUS) (must have controller software version 08 or greater)

- Enter **inSt** Menu.
- Press **↑** then **8** to enter **PLUS** sub menu. The sign will display **PLUS**.

### Brightness Offset by Line

- Brightness Offset by Line is used to adjust the brightness of one line of digits relative the rest of the digits on the sign.
- Press **↑** then **4** to enter the Brightness Offset by Line sub menu.
- The selected line will display **BBBB** and all other lines will display **0000**.
- To brighten the selected line of digits press **2**.
- To dim the selected line of digits press **8**.
- To select the next line of digits press **6** or **OK**.
- To select the previous line of digits press **4**.
- When the last line of digits is selected press **OK** to save and exit to **PLUS** sub menu.

### Brightness Offset by Digit

- Brightness Offset by digit is used to adjust the brightness of each of digit relative the rest of the digits on the sign.
- Press **↑** then **5** to enter the Brightness Offset by Digit sub menu.
- The selected digit will display **B** and all other digits will display **0**.
- To brighten the selected digit press **2**.
- To dim the selected digit press **8**.
- To select the next digit press **6** or **OK**.
- To select the previous digit press **4**.
- When the last digit is selected press **OK** to save and exit to **PLUS** sub menu.

### Reset Brightness Offsets

- Resets all brightness offsets back to default.
- Press **↑** then **6** to enter the Reset Brightness Offset sub menu.
- **CLER** will appear, enter **123** then press **OK** to confirm.
  - If the code was entered incorrectly, the sign will display **FR IL**.
    - Press **OK** to return to **PLUS** menu.
  - If the code was entered correctly, the sign will exit **PLUS** menu.

### Decimal Point (/10) Enable / Disable

- Allows decimal points and the (/10 portions of digits if present) to be turned on and off.  
**Note:** The decimal must be physically present or enabling/disabling it will have no effect.
- Press **↑** then **7** to enter the Decimal Point Enable / Disable sub menu.
- The selected digit will flash.
- To enable the decimal connected to the selected digit press **1**.
- To disable the decimal connected to the selected digit press **0**.
- To select the next digit press **6** or **OK**.
- To select the previous digit press **4**.
- When the last digit is selected press **OK** to save and exit to **PLUS** sub menu.

# Section 13: Economy Remote Installer Menu

## Advanced Options (PLUS) (must have controller software version 08 or greater)

- Enter **inSt** Menu
- Press **↑** then **8** to enter **PLUS** sub menu. The sign will display **PLUS**

### Disable Leading Zeros (bLr)

- Disable leading zeros is used to turn off and on leading zeros for all products on the sign.  
**Note:** With this option enabled, leading zeros will only be shown when updating prices in the user menu or with the PricePad.
- Press **↑** then **8** to enter the blanking zeros sub menu.
- Press **0** to change between **on** and **OFF**.
  - **YES** - Enable blank leading zeros.
  - **no** - Disables blank leading zeros.
- Press **OK** to save and return to **PLUS** menu.

### Daylight Savings Enable / Disable

- Press **↑** then **9** to enter the Daylight Savings Time enable / disable sub menu.
- Press **0** to change between **USA** and **OFF**.
  - **USA**- Enable daylight savings time following USA rules starting in 2007.
  - **OFF** - Disables daylight savings time.
- Press **OK** to save and return to **PLUS** menu.

## Select Product Type (must have controller software version 10 or greater)

Every product can be set to 1 of 4 different types. If a product is setup to toggle between multiple payment methods each payment method can be setup as a different type.

- 1) **Price:** Numeric display where value must be updated with economy remote or PricePad.
  - 2) **Counter:** Numeric display that will automatically count at a configurable rate and direction.
  - 3) **Clock:** Displays the current time in 12-hour or 24-hour mode.
  - 4) **Temperature:** Displays the current temperature in deg C or F.
- Enter **inSt** Menu.
  - Press **↑** then **9** to enter the select product type menu.
  - The first payment method of the first product will display its product type. Press **0** to cycle between the 4 payment types **Pr iC** (Price), **Cntr** (Counter), **ti** (Timer), **CL**(Clock), and **EP** (Temperature) until the desired product type is selected.
  - Setup the selected product type with type specific options.

**Price Pr iC** - No price specific configuration needed.

### Counter Cntr

#### Counter Direction:

- Press **↑** then **1** to change the counter direction.
- Toggle between the counter directions **POS** (Positive, count up) or **NEG** (Negative, count down) by pressing **0**.
- With the correct counter direction selected press **OK**.

## Section 13: Economy Remote Installer Menu

- **Counter Rate:** Determines the speed at which the counter counts. The speed the counter counts at is equal to *Counter Rate x Counter Time Base x 0.1 seconds*.  
Example: to count once per day set counter time base to 600 (60 seconds) and the counter rate to 1440 (1440 minutes per day with a time base of 1 minute). Note: If the counter rate or counter time base is set to 0 the counter will not count.
  - Press  $\uparrow$  then  $\textcircled{2}$  to change the count rate.
  - Enter desired count rate (1 to 9999) and press  $\text{OK}$ .
- **Counter Time Base:**
  - Press  $\uparrow$  then  $\textcircled{3}$  to change the count time base.
  - Enter desired count time base (1 to 9999) and press  $\text{OK}$ .
- **Counter Mode:** There are 3 counter modes.
  1. **Count:**  $\text{Cn}$  - User enters the desired initial count and the sign immediately starts counting.
  2. **Time and Date:**  $\text{dAtE}$  - User enters the future and date they want to count to (negative count direction) or the previous date they want to count from (positive count direction).
  3. **Count + Time and Date:**  $\text{CdAtE}$  - User enters an initial count and the time and date of the initial count.
  - Press  $\uparrow$  then  $\textcircled{4}$  to change the counter mode.
  - Toggle between the counter modes  $\text{Cn}$  (Count),  $\text{dAtE}$  (Time and Date), and  $\text{CdAtE}$  (Count + Time and Date) by pressing  $\textcircled{0}$ .
  - With the correct counter mode selected press  $\text{OK}$ .

### Clock $\text{CL}$

- 12-hour /24-hour display mode:
  - Press  $\uparrow$  then  $\textcircled{1}$  to change the hour display mode.
  - Toggle between  $\text{12h}$  (12-hour mode) and  $\text{24h}$  (24-hour mode) by pressing  $\textcircled{0}$ .
  - With the correct mode selected press  $\text{OK}$ .
- Flash colon option enable / disable:
  - Press  $\uparrow$  then  $\textcircled{2}$  to change the flashing colon option.
  - Toggle between  $\text{YES}$  (colon flashes every second) and  $\text{no}$  (colon stays on steady) by pressing  $\textcircled{0}$ .
  - With the correct option selected press  $\text{OK}$ .

## Section 13: Economy Remote Installer Menu

### Temperature $\text{E}P$

- C° / F° display mode:
  - Press  $\uparrow$  then  $\text{1}$  to change the C° / F° display mode.
  - Toggle between  $F$  (Fahrenheit) and  $C$  (Celsius) by pressing  $\text{0}$ .
  - With the correct mode selected press  $\text{OK}$ .
- Temperature offset:
  - Press  $\uparrow$  then  $\text{2}$  to change the temperature offset.
  - Toggle between  $POS$  (Positive) and  $NEG$  (Negative) offset direction by pressing  $\text{0}$ .
  - With the correct offset direction selected press  $\text{OK}$ .
  - Enter the temperature offset value in degrees from 0 to 99 and press  $\text{OK}$ .
- Temperature Sensor Selection:
  - Press  $\uparrow$  then  $\text{3}$  to select the desired temperature sensor.
  - If multiple sensors are connected press  $\text{0}$  to toggle through available sensors.
  - With the correct sensor selected press  $\text{OK}$ .

### Factory Reset

Factory reset will erase all configurations, user settings, and readdress all digits. It will not affect the current user or installer code.

- Enter  $\text{Inst}$  Menu.
- Press  $\uparrow$  then  $\text{0}$  to enter the Factory Reset sub menu:
  - The sign will display  $\text{rEst}$ .
- Enter safety code **90152953** using the remote:
  - Every key press will make  $\text{rEst}$  flash.
- Press  $\text{OK}$  to start the factory reset:
  - If the code was entered incorrectly, the sign will display  $\text{FA IL}$ :
    - Press  $\text{OK}$  to return to  $\text{Inst}$  menu.
  - If the code was entered correctly, the sign will exit  $\text{Inst}$  menu and reset the sign.

# Section 14: Economy Remote Summary

## User Menu

Type User Code to Enter  
User Menu (USER)  
User Code \_ \_ \_ \_

- OK Save & Advance
- OK OK Exit User Menu
- 1 1 Set Price(s)  
Type New Price
- 2 Enable/Disable Products  
0 Toggles
- 4 Set Clock (24hour)  
Time: **CL** HHmm  
Date: **CD** MMdd  
Year: **CY** YY
- 5 Sign On/Off Timer  
**on** HHmm **OFF** HHmm
- 6 Sign Bright Timer  
Day: **brH** HHmm  
Night: **brLo** HHmm
- 7 Manual Light Level  
0 Toggles
- 8 Day Light Level  
Range: 00 - 99
- 9 Night Light Level  
Range: 00 - 99

**Note:** Pressing **OK** enough times will exit out of any menu and back to normal sign operation

## Installer Menu

Type Installer Code to Enter Installer Menu (Inst)  
Installer Code: 74191 38635

- OK Save & Advance
- OK OK Exit Installer Menu
- 1 1 Set Number of Faces  
(1 - 4) Faces
- 2 Set Wire Direction  
(1 - 6) valid wire directions
- 3 Product Mapping  
Assign Product Numbers
- 4 Sign Information (Inf)  
1 1 Digit Software Version  
1 2 Controller Software Version  
1 3 Digits Addressed  
1 4 Internal Temperature  
1 5 Power Supply Test Results  
1 6 Start Power Supply Test
- 5 Change User Code  
Enter new code OK  
Re-enter to confirm OK
- 6 Set Time Zone (UTC offset)  
**Pos**(positive) or  
**neg** (Negative) toggle 0  
OK enter value (0 - 12)

## Installer Menu continued

- 7 Display Settings (d.SP)
  - 1 1 Number of Payment Methods (1 to 8)
  - 2 Payment Display Time (time base 100ms)
  - 3 Display Text Selection
  - 4 Display Text Editor
  - 5 Display Number
  - 6 Display Position (X, Y) Coordinates
  - 0 Display Reset
- 8 Advanced Options (PLUS)
  - 1 1 9/10 Digit Value  
**Stat** (static) or  
**Prog** (Programmable) toggle 0  
If **Stat** enter value (0 - 9)
  - 2 Light Sensor Relay Settings  
**LP** Light Sensor Percentage  
**Lt** Relay Light Sensor Threshold  
**LH** Relay Light Sensor Hysteresis
  - 3 Light Sensor Min Max Settings  
**Sr** Light Sensor Reading  
**SL** Sensor Low Limit  
**SH** Sensor High Limit
  - 4 Brightness Offsets by Line
  - 5 Brightness Offsets by Digit
  - 6 Reset Brightness Offsets  
**CLEr**: 123 OK
  - 7 Decimal Point Enable / Disable
  - 8 Disable Leading Zeros (**bln**) toggle 0
  - 9 Daylight Savings Time toggle 0
- 9 Select Product Type
  - 0 Toggles between following types  
**Pr** **CL** (Price display)  
**Cnt** (Counter display)  
1 1 Count direction  
1 2 Count rate  
1 3 Count time base  
1 4 Counter Mode  
**CL** (Clock display)  
1 1 12 / 24 Hour Mode  
1 2 Flash Colon  
**tP** (Temperature display)  
1 1 Temperature in C / F  
1 2 Temperature offset  
1 3 Temperature Sensor Selection
  - OK Advances to the next payment method / product
- 0 Reset Sign  
**rEst**: 9015295 OK

# Section 15: PricePad Operation

The PricePad is used to wirelessly update the prices and settings of LED gas price signs (EPCU 3.0).

## 15.1 PricePad Setup

1. Attach the antenna to the PricePad.
2. If the POS option has been ordered. Connect the supplied USB or RS-232 POS cable to the PricePad and the POS system.
3. Plug the AC adaptor into an outlet and connect it to the PricePad.

## 15.2 PricePad Operation

The PricePad is equipped with a color touch screen allowing prices and settings to be updated with just a few taps on the screen with a finger.

**Note: The screen will automatically shut off after 5 minutes without use. Tapping anywhere on the screen will turn it back on.**



### Menu Navigation:

- Tap items on screen to enter the corresponding menu or to edit a value.
- To return to the previous menu, press the “Back” button in the bottom left of the screen.
- There are 3 main types of edit screens.
  - **Number entry** – Allows a number to be updated. Change the value by using the onscreen keypad. The arrow keys will move the cursor left and right.
  - **Text entry** – Allows text to be entered. The shift key will switch the keyboard between lowercase and uppercase letters. The insert key will switch between insert and overwrite text entry mode. The backspace key will delete the previous character.
  - **Spinners** – Allow settings to be selected from a list of possible options. (Example a date) To change the value touch and drag up or down over the value.
  - After editing a setting, tap the “Save” button to save the changes. Tap the “Back” button to cancel any changes.
  - During the saving process, a busy indicator will spin in the upper right-hand corner of the screen.
- If there are more than 6 items in a menu, arrow keys will appear on the left, right, or both sides of the screen allowing navigation between menu pages.



# Section 15: PricePad Operation

## 15.3 Startup



The Loading screen is displayed when the PricePad is first powered on. After communication has been successfully established, the “Price” menu will be displayed.

## 15.4 Changing Prices



### Price Menu:

- This is the main screen and will be shown after loading has completed.
- To change a price:
  - Tap the price or name of the product that needs to be changed.
  - Edit the value using the keypad.
  - Tap “Save” to update the price on all signs.
  - When the price screen returns, all signs will have been successfully updated to the new price.



## 15.5 Signal Strength



### Signal Strength:

- Signal strength is indicated by the green bars in the upper right corner of the screen. Tapping these bars will display the “Signal” menu.
- The “Signal” menu displays the signal strength of each sign bound to the PricePad.
- Signal strength ranges from 0 to 4 bars.
  - 3 or 4 bars indicate good signal strength.
  - 2 bars indicate low signal strength.
  - 1 bar indicates very low signal strength. With one bar it may take longer to update the sign and communication errors may occur.
  - 0 bars indicate the sign is out of range.

**Note:** If the PricePad is used to control multiple signs, the green bars in the upper right corner will indicate the lowest signal strength of any sign.

# Section 15: PricePad Operation

## 15.6 Settings

Touch to enter Settings menu



To enter the Settings Menu:

- Tap the gear in the upper right corner of the screen.

Settings Menu:

The “Settings” menu contains the following sub menus.

- **Products** – Rename, enable, or disable products.
- **Clock** - Set the time and date.
- **Brightness** - Change the sign brightness and light mode.
- **Timers** - Setup timers to turn the sign on or off and dim the sign at night.
- **Info** - Display PricePad and sign information.
- **Advanced** - Access advanced settings.



Products Menu: → Products

The “Products” menu is used to enable or disable products, to name products, and to name prices.

- Tap the product that needs to be changed.
  - In this menu, tap a setting to change its value.
    - **Enabled?** : Turns the product on or off on all signs.
    - **Product Name:** Sets the product name to be used on the PricePad. (ex. Regular, Premium, Diesel)
    - **Price Name:** Sets the price name to be used on the PricePad. Price names are only displayed if the product has multiple prices. (ex. Cash / Credit toggle)

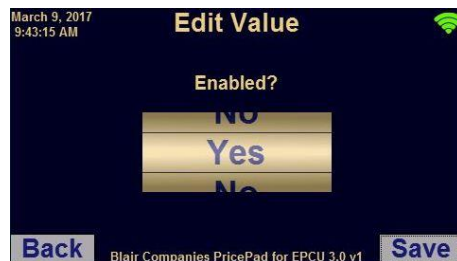

# Section 15: PricePad Operation

## 15.6 Settings (continued)



### Clock Menu: ⚙️ → Clock

- Tap a setting to change its value.
  - **Time:** The current time used by the sign and the PricePad.
  - **Date:** The current date used by the sign and the PricePad.
  - **Daylight Savings Time:** Enables or disable automatic time changes for daylight savings time.

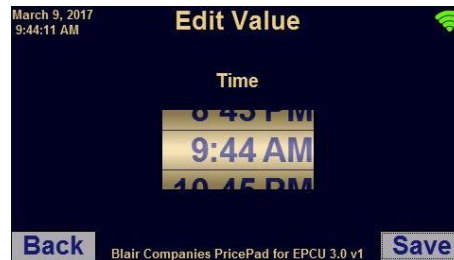

### Brightness Menu: ⚙️ → Brightness

- Tap a setting to change its value.
  - **Day Brightness:** Changes how bright the LED's are on the sign during the day. Then sign needs to be brighter during the day to be readable in sunlight.
  - **Night Brightness:** Changes how bright the LED's are on the sign at night. The sign should be dimmer at night to be readable.
  - **Note:** The default Day Brightness is 99. The default Night Brightness is 49. Lower brightness values make the sign dimmer.
  - **Light Mode:**
    - **Timers** – Sign power will be controlled with the On/Off timer and brightness will be controlled with the Day/Night timer.
    - **Photocell** - Sign power will be controlled with the On/Off timers and brightness will be controlled with a photocell.
    - **Note:** The sign must be equipped with a photocell for this mode to work correctly. If a photocell is not present the sign will always stay at the night brightness level.
    - **Day** – Sign will stay at day brightness. Timers and photocell input will be ignored.
    - **Night** – Sign will stay at night brightness. Timers and photocell input will be ignored.
    - **Off**– Sign will stay off. Timers and photocell input will be ignored.

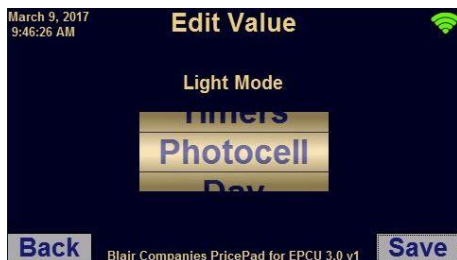
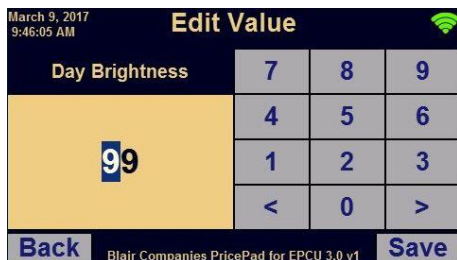

# Section 15: PricePad Operation

## 15.6 Settings (continued) Timers Menu: ⚙️ → Timers



- Tap a setting to change its value.
  - **On/Off Timer:** Controls when the sign automatically turns on and off.
    - **Sign on 24 Hours?:** Setting this to “Yes” will keep the sign on 24 hours a day and hide the “Sign On” and “Sign Off” times from the menu.
    - **Sign On:** The time the sign will turn on. (store open time)
    - **Sign Off:** The time the sign will turn off. (store close time)
  - **Day/Night Timer:**
    - **Day Start:** Time when the digits change from night brightness to day brightness and the sign’s lights shut off.
    - **Night Start:** The time when the sign goes from day brightness to night brightness and the sign’s lights turn on.
- Note:** The Day/Night timer will not be available if the light mode is set to Photocell.

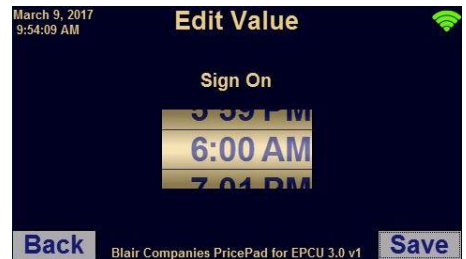

## Info Menu: ⚙️ → Info

The Info menu displays PricePad and sign information, and allows sign names to be changed.

- The following PricePad information is displayed:
  - PricePad startup time and date.
  - PricePad serial number.
  - All signs currently bound and their signal strengths.
- To view sign specific info, tap the desired sign.
- The sign address, controller firmware version, and sign name is displayed.
- The sign name can be changed by tapping it, then using the onscreen keyboard to enter a new name. This is useful if there are multiple signs.



# Section 15: PricePad Operation

## 15.7 Advanced Settings

The Advanced Settings menu contains additional settings that should not need to be changed on a regular basis.

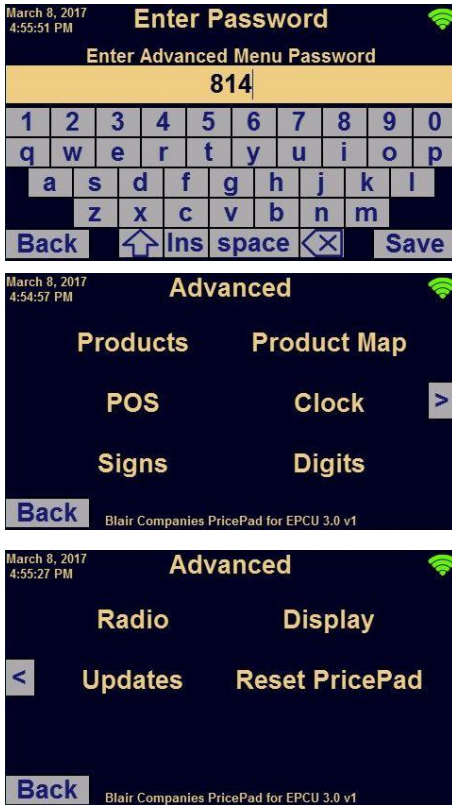

To enter Advanced Menu: → **Advanced**

- Tap Advanced in the Settings menu.
- Enter password: 814
- Tap “Save”

**Advanced Menu:**

- **Products:** Change the number of product or prices. Enable/disable decimal points and the “/10” portion of 9/10 digits.
- **Product Map:** The product map allows any product price combination on a sign to be mapped to any product price combination on the PricePad.
- **POS:** Setup POS integration allowing a POS system to automatically update prices.
- **Clock:** Change the clock display between 12-hour and 24-hour mode.
- **Signs:** Bind to new signs, delete old signs, identify signs, and change the “Number of Faces” setting on each sign.
- **Digits:** Change the behavior of the small 9 or 9/10 digit.
- **Radio:** Switch between internal and external radios.
- **Display:** Flip the display. (This is used when mounting the PricePad to the wall so the cables can face down)
- **Updates:** Upgrade the firmware.
- **Reset PricePad:** Resets all PricePad settings (will unbind all signs and return settings to defaults)

# Section 15: PricePad Operation

## 15.7 Advanced Settings (continued)



Advanced Products Menu: → Advanced → Products

- **Number of Products:** The number of products the PricePad will display. If the PricePad is setup to have more products than the sign, the extra products on the PricePad will have no effect on the sign.
- **Product Settings:** Tap the product's name to change its settings.



- **Enabled?** : Turns the product on or off on all signs.
- **Number of Prices:** The number of prices that will be displayed on a single product line. Normally this should be set to 1. If the product toggles (ex. Cash / Credit) the number of prices should be set to the number of prices the product toggles between.
- **Product Name:** Sets the product name to be used on the PricePad. (ex. Regular, Premium, Diesel)
- **Decimal Point:** The decimal point outputs on each digit can be enabled or disabled for each price. This also affects how prices are displayed on the PricePad.

**Note:** See figure for correct settings.

**Note:** This only enables the output; the decimal point has to be installed on the sign for it to have any effect.

**Note:** The rightmost checkbox will enable/disable the /10 portion of a 9/10 if it is present on the sign.

- **Price Name:** Sets the price name to be used on the PricePad. Price names are only displayed if the product has multiple prices. (ex. Cash / Credit toggle)

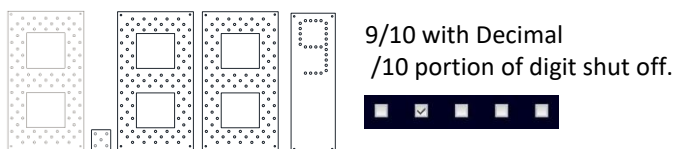
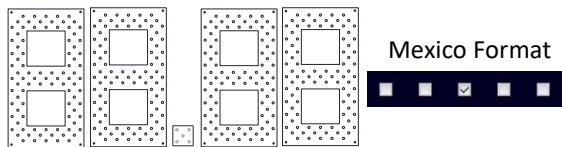
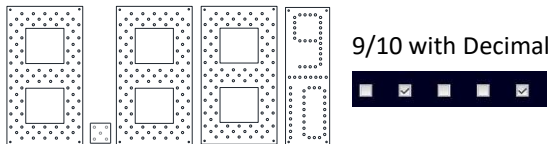
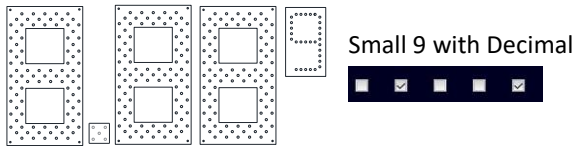
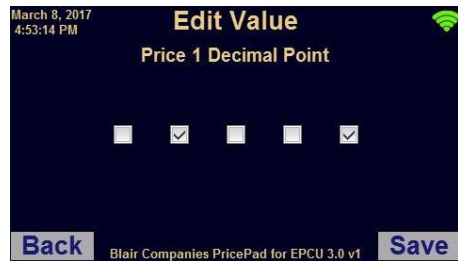

# Section 15: PricePad Operation

## 15.7 Advanced Settings (continued)



**Advanced Products Menu:** ⚙️ → **Advanced** → **Product Map**

A Product is made up of one or more lines of digits that can display a single price or toggle through multiple prices. The product map allows any product price combination on a sign to be mapped to any product price combination on the PricePad.



**Reasons for changing the product map:** Product map changes may only be required if the PricePad is bound to multiple signs and one of the following is true:

- The products are not in the same order on all the signs.
- Not all products are shown on all signs.
- A cash / credit toggle combined with a second sign with cash and credit on separate lines.



**To Update Product Map:**

- Tap a sign, then a line on that sign, then the price on that line.
- Choose the PricePad product from the list that should display on the sign-> line-> price.

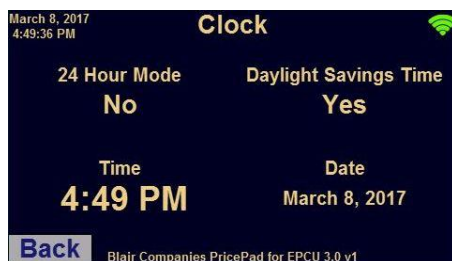

**Advanced Clock Menu:** ⚙️ → **Advanced** → **Clock**

- Tap a setting to change its value.
  - **24-Hour Mode:** Switches time display and entry from 12-hour mode to 24-hour mode.
  - **Time:** The current time used by the sign and the PricePad.
  - **Date:** The current date used by the sign and the PricePad.
  - **Daylight Savings Time:** Enables or disable automatic time changes for daylight savings time.

# Section 15: PricePad Operation

## 15.7 Advanced Settings (continued)

### POS (optional Point of Sale Integration)

POS integration is a feature that allows the POS system to directly change prices on the PricePad without operator intervention. The following POS systems are currently available:

- Verifone
- Gilbarco
- Radiant / NCR

POS integration is a software option, at extra cost. The POS option can be factory ordered or field upgraded. When field upgrading, an unlock code and communication cable will be provided. The PricePad supports RS-232 or USB communication for all POS systems.

POS Menu:  → **Advanced** → **POS**

- **Pos Mode:** Used to activate or switch POS systems. After a POS mode is activated, then additional settings will be available. To obtain a POS unlock code, contact Blair Companies.  
**Note:** If the Pos Mode is currently set to one of the available POS's, entering an invalid code will set the Pos Mode back to No POS.  
**Note:** If a POS has been activated on the PricePad, the activation code should be on a sticker applied to the bottom of the PricePad.

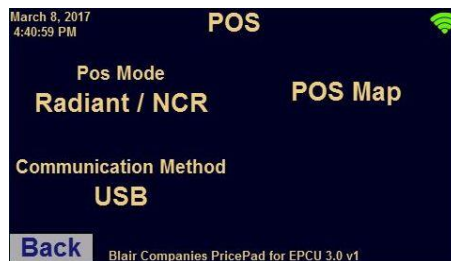
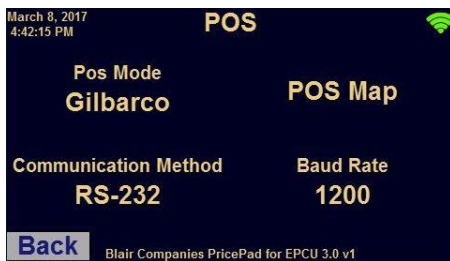
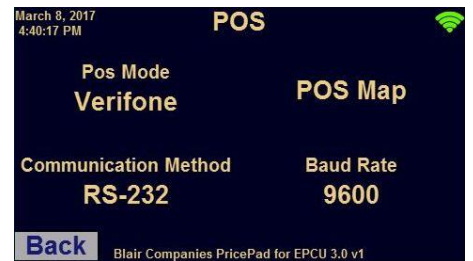
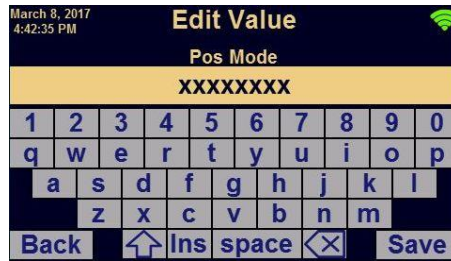
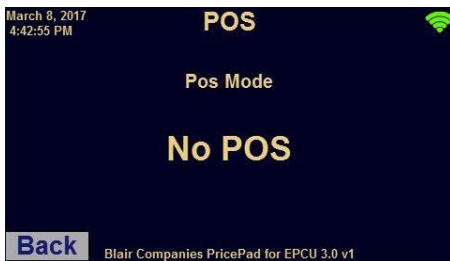

# Section 15: PricePad Operation

## 15.7 Advanced Settings (continued)

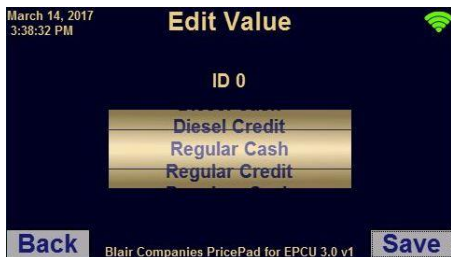
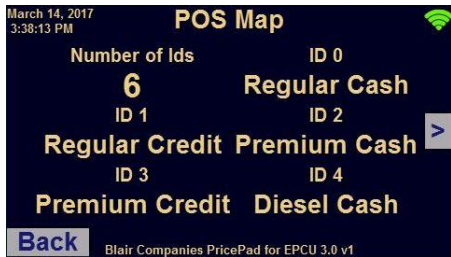

### POS (optional Point of Sale Integration) continued

- **Communication Method:**
  - **USB** - POS is connected to the PricePad with a micro USB cable.
  - **RS-232** - POS is connected to the PricePad with a Blair Companies supplied cable. The connection is labeled "POS" in the PricePad.
- **Baud Rate:** Only available if the communication method is set to RS-232. Available baud rates(1200, 2400, 4800, 9600, 19200, 38400, 57600, or 115200)
 

**Note:** The following settings are used for RS-232 communication and are not configurable:

  - Data: 8bits
  - Stop: 1 bit
  - Parity: None
  - Flow Control: None

**Note:** The default communication method and baud rate will be set when the POS activation code is entered.

**Note for Verifone POS systems:** The Verifone POS system must have its decimal point option set to 3 for each price.
- **POS Map (PricePad Firmware v1 – 18):** The POS map is used to map a POS's product ID to a product or product price combination on the PricePad.
  - **Number of Ids:** The "Number of Ids" should be set to the number of products or price product combinations on the PricePad. The max number of IDs supported varies by POS: Verifone 36, Gilbarco 8, NCR 8, Dresser Wayne 36.
  - **ID:** The POS assigns an id to each price it controls on the sign. Each id can be mapped to any price. (For example, Regular Cash and Regular Credit would map to separate POS IDs.)

# Section 15: PricePad Operation



## POS (optional Point of Sale Integration) continued

- **POS Map (PricePad Firmware v19 and up):**  
A POS ID is a number from 0 – 99 that the POS uses to identify that product. The range of valid ID's varies by POS system. The POS can send different prices to each id. The POS map allows products on the PricePad to be assigned to a POS ID. One or more products can be assigned to each POS ID.  
**NOTE:** By default, all products have a POS ID = 0. The id's must be updated on the PricePad to match the POS.
- **POS Discount (PricePad Firmware v19 and up):** The POS Discount allows a discount to be applied to the price sent from the POS before it is displayed on the PricePad.
  - Example: POS sends 3.99 for ID 1.  
Reg Credit and Reg BP me Visa are mapped to ID 1.  
Reg Credit has no offset so it's set to 3.99.  
Reg BP me Visa has a 0.15 discount so it displays 3.84.

# Section 15: PricePad Operation

## 15.7 Advanced Settings (continued)



### Signs Menu: ⚙️ → Advanced → Signs

The sign settings menu allows signs to be added (bound) and deleted (unbound) from the PricePad. It allows signs to be identified, and the “Number of Faces” setting on each sign to be changed.

#### Adding a New Sign (Binding):

- Press the “New” button.
- Follow the on-screen prompt and power cycle the sign. Then press the “Scan” button.
- Wait for scanning to complete. This may take up to a minute.
- Tap the address of a sign that is ready to bind.
- If there are multiple signs ready to be bound like in the image to the left, pick one by tapping it. Then press “Identify”. This will cause the sign to blink slowly.
- If the correct sign is selected press “Bind” if not press “Back” and try another sign.
- Wait for Binding to complete.
- Press “Back” on the Binding Complete screen.
- If multiple signs were ready to bind, and another on the list needs to be bound, it can be bound at this time.

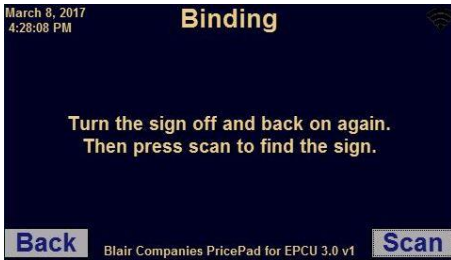

#### Sign Settings:

- **Address:** Unique address of the sign (read only).
- **Identify:** Button that causes the sign to blink slowly so it can be identified.
- **Sign Name:** The sign name can be changed for easy sign identification. This is useful if multiple signs are bound to the PricePad.
- **Number of Faces:** Setting on the sign that controls how many sides the sign has. For a normal 2-sided sign “Number of Faces” should be set to 2.
- **Controller Ver.:** Displays controller firmware version (read only).
- **Delete:** The “Delete” button will delete (unbind) the sign from the PricePad.

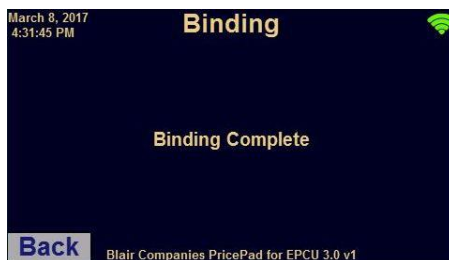
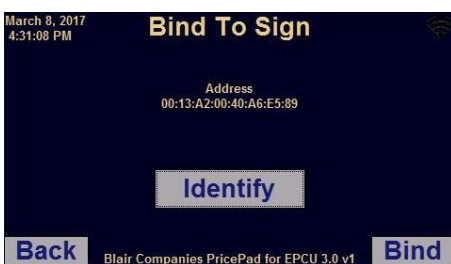

# Section 15: PricePad Operation

## 15.7 Advanced Settings (continued)



**Digits Menu:** ⚙️ → Advanced → Digits

- **Force Last Digit?:**
  - **Yes** – Prevents the user from changing the value of the last digit (9/10 digit) when entering a price.
  - **No** – Allows the user to change the value of the last digit (9/10 digit) when entering a price.
- **Last Digit Value:** Value displayed on the last digit (9/10 digit) if “Force Last Digit?” is set to “Yes”.

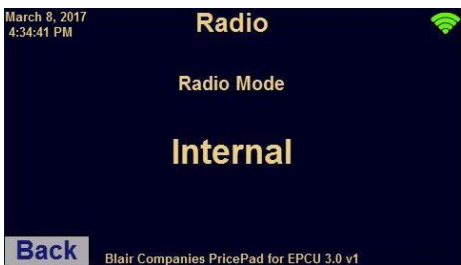

**Radio Menu:** ⚙️ → Advanced → Radio

- **Radio Mode:** The radio mode can be switched to allow an external radio to be connected for improved signal strength
  - **Internal** – Use the internal radio.
  - **External** – Use an external radio connected to the COM port on the PricePad.

**Note:** If the radio mode is switched to External and an external radio is not connected, communication with the sign will no longer work.



**Display Menu:** ⚙️ → Advanced → Display

- **Flip Display:** The display menu allows the screen to be flipped 180° (useful when mounting the PricePad to a wall).
  - **No** – Normal mode for countertop operation where the PricePad cables will face away from the user.
  - **Yes** – Flipped mode will flip the screen 180° so the PricePad can be mounted on a wall and the cables face down.

# Section 15: PricePad Operation

## 15.7 Advanced Settings (continued)

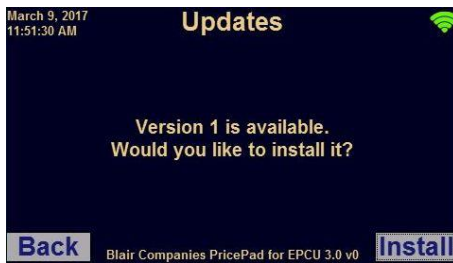

**Updates Menu:** ⚙️ → **Advanced** → **Updates**

The updates menu allows the PricePads firmware to be field upgraded.

**To update the PricePads firmware:**

- Plug an internet connected Ethernet cable into the port on the PricePad.
- Navigate to the Updates menu.
- The screen will display “Checking for Updates...” if an active network cable is connected. If a network cable is not connected, the screen will display “The network cable is disconnected.”
- If “Checking for updates Failed. Press ‘Retry’ to try again” appears, the PricePad was unable to connect to the update server.

**Causes:**

- Ethernet cable not connected to PricePad.
- Internet connection not available.
- Update server offline.
- After successfully connecting to the update server one of two screens will show.
  - “No updates are available at this time”
  - “Version x is available. Would you like to install it?”
- If a new version is available, tap “Install”.
- Wait for the install process to complete (do not interrupt the install process). When it is complete, the PricePad will reboot.

⚙️ → **Advanced** → **Reset PricePad**

**Reset PricePad Menu:** Resets all PricePad settings to factory defaults and unbinds all signs.

- Follow onscreen prompts to reset PricePad.

# Section 15: PricePad Operation

## 15.8 Error Screens

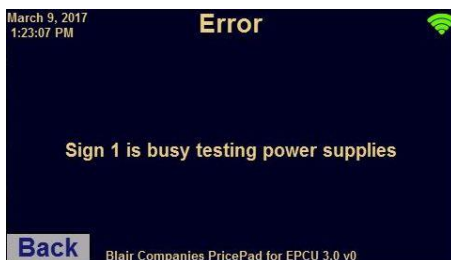

### Communication Errors

All errors will self clear 60 seconds after the error condition is removed. Pressing the Back button will immediately clear the error.

#### Causes for Errors:

##### Cannot communicate with Sign:

- The sign is powered off.
- The PricePad radio is out of range of the sign.
- The antenna on the PricePad or sign is damaged or not present.
- The sign side radio is not working properly.

##### External radio selected and not responding:

- Radio Mode is set to “external” and the external radio is not securely plugged into the COM connector on the PricePad.
- Radio Mode is set to “external” and external radio is not working properly.

##### Internal radio selected and not responding:

- Radio Mode is set to “internal” and the PricePad is not equipped with an internal radio.
- Radio Mode is set to “internal” and the internal radio is not working properly.

### Sign Busy Errors

#### Sign is busy in economy remote menu:

- This error will go away after exiting the economy remote menu.

#### Sign is busy performing factory reset:

- This error will go away after the factory reset is complete.

#### Sign is busy testing power supplies:

- This error will go away after the 1 minute supply test has completed.

#### Sign is busy testing digits:

- Dipswitch 3 is in the on position on the master controller causing the sign to perform a digit test.



## Section 16: Troubleshooting

Problem	Cause	Solution
LED or Fluorescent lights controlled with gas price sign will not turn on or are stuck on	Incorrect time	Set clock
	Incorrect timer settings	Check timer setting
	Light level overridden	Set light level to "Auto"
	Light sensor giving incorrect reading (if present)	Change light sensor min and max values. If desired results cannot be reached, replace light sensor
	Relay cable loose or corroded	Reconnect or replace relay cable
	AC distribution board relay not working	Replace AC distribution board
	Relay output is not working on controller	Replace controller
Econo Remote will not work	Remote is turned off	Turn on remote
	Battery in remote is dead	Replace battery
	Out of range of sign	Extend antenna and walk closer to sign
	The incorrect "User" code is being entered	Enter installer menu and reset "User" code
	Sign does not recognize remote	Rebind remote to sign
	Econo Remote is not working	Replace Econo remote
	Receiver on controller board is not working	Replace master controller board
PricePad cannot communicate with local radio	Internal radio error	Power Cycle PricePad
	Sign communication port on PricePad has stopped functioning	Replace PricePad
PricePad cannot reach sign	PricePad is out of range of sign	Move PricePad side radio closer to sign with a clear line of sight
	PricePad is not bound to sign	Rebind PricePad to sign, cycling power on the PricePad will show the number of signs bound on boot screen
	Antenna not installed properly on exterior of sign	Install antenna on exterior of sign on side facing PricePad radio
	Antenna cable is loose	Tighten antenna cable
	Radio is not functioning on master controller	Replace master controller

## Section 16: Troubleshooting

Problem	Cause	Solution
All LEDs on sign are off, but PricePad still communicates with sign	The timers turned off the sign, or the sign light level has been set to Off	Set light level to "Auto"
		Set PricePad clock
		Correct store open and closed timer values
	Check that products are enabled	
	Digit cables are loose	Check digit cables
All LEDs on sign are off, PricePad and Econo remote cannot communicate with sign	Sign has lost power	Check breaker in store and switch at sign pole, ensure sign has power
	AC distribution board is damaged by power surge	Replace AC distribution board
	Bad power supplies (AC present on distribution board but all power supply outputs are less than 11 volts)	Replace power supplies
	Bad controller board (power supply outputs greater than or equal to 12 volts)	Replace controller board
One or more digits are displaying a single dash or appears frozen	Internal Error	Power cycle sign
	Invalid Configuration	Readdress digits
		Reset sign to factory defaults
	Loose or corroded digit cable	Check digit cables
	Defective digit	Replace digit
Digits connected to a channel are displaying a single dash or appears frozen. The LED next to digit channel on the controller board stays on steady.	Communication to all digits on the channel is being disrupted by a bad digit	Identify faulty digit by disconnecting digits until the LED next to the digit channel on the controller goes out or starts flashing, then replace the faulty digit
One or more digits are displaying three dashes	There are too many digits connected to a single channel	Reconnect digit following max digits per channel guideline, then reset sign to factory defaults
Some but not all digits connected to a controller are completely off	Loose or corroded digit cable	Check digit cables
	Defective digit	Replace digit
One or more LEDs on a digit will not light up	Digit is defective or has been damaged	Replace digit
Sign is operating at reduced brightness	Incorrect light level setting	Check day and night light levels
	Incorrect time	Set clock
	Incorrect timer settings	Check timer setting
	Light level overridden	Set light level to "Auto"
	Light sensor giving incorrect reading (if present)	Change light sensor min and max values. If desired results cannot be reached replace light sensor.
	Internal Temperature in sign is too high	Install vents in sign
	Power supply failure (run power supply test to confirm)	Replace power supply

## Section 16: Troubleshooting

Problem	Cause	Solution
All digits attached to a slave controller are off or frozen	Internal error	Power cycle sign
	Invalid configuration	Readdress digits
		Reset sign to factory defaults
	Controller link communication cable loose or corroded	Check Inner board communication cable
	Slave controller board address set incorrectly	Set address correctly
	Slave controller does not have power	Check AC supply, AC distribution board output, and Power supplies
Slave controller board is not communicating with master controller	Replace slave controller. If problem persists, replace master controller board	
Sign does not remember prices after being power cycled	Corrupt memory in master controller	Replace master controller
Sign loses time when power cycled	Dead battery on controller	Replace controller
Time on sign changes by 1 hour in the Spring and Fall	Daylight savings time is enabled	Disable daylight savings time function if desired.
Sign always displays "8888" at startup then goes to displaying prices or "1119"	Switch 1 or 2 on the master controller was left in the <b>ON</b> position causing the sign to rest or readdress digits at startup	Turn <b>OFF</b> switch 1 and 2 on the master controller
Text is cut off on text display	Improper display configuration	See section 12 display configuration for details
	To many characters for size of display	Decrease number of characters or add an additional display

### Blair Image Service

(814) 949-8287 x717

[service@blairimage.com](mailto:service@blairimage.com)

### Blair Image 24 hr Emergency Service

**(This is not for after-hours Installation/service or activation)**

**800-563-9598**

# Section 17: Maintenance

## Controller Replacement Instructions

1. Power off the sign.
2. Disconnect cables from old controller board. (Note where cables are connected).
3. Remove old controller board from DIN rail.
4. Install new controller board onto DIN rail.
5. Connect all cables to the new controller in the same order as they were connected to the old controller.
6. Power on the sign.
7. Perform a Factory Reset by turning dipswitch 1 to ON.  
**Important:** After the factory reset is complete, turn OFF dipswitch 1.
8. Bind existing economy remote:
  - a. Power cycle sign.
  - b. With the remote on and in range of the sign hold **6** and **9** buttons down at the same time.
  - c. The sign will flash, when it stops flashing power cycle the sign again.
  - d. Hold **6** and **9** buttons down at the same time again.
  - e. The sign will flash **bind** then go to normal price display the remote is now bound.
9. Set the User Code to match the code written on remote (if the sign displays **Code** skip to step c)
  - a. Enter the installer menu by entering the installer code **741918635**. The sign will display **inst\_**
  - b. Press **↑** then **5** on the remote.
  - c. The sign will display **Code**.
  - d. Enter the desired user code written on the remote.
  - e. Press **OK**.
  - f. Enter the same code again to confirm.
  - g. Press **OK**.
  - h. The sign will display **PASS**.
  - i. If the sign displays **FAIL** restart with step 9b.

## AC Distribution Board Replacement Instructions

1. Power off the sign.
2. Disconnect cables from old ac distribution board. (note where cables are connected).
3. Remove old AC distribution board from DIN rail.
4. Install a new AC distribution board onto DIN rail.
5. Reconnect all cables to the new AC distribution board.  
**Important:** Take protective caps from unused output channels on old AC distribution board and put them into unused channels on new AC distribution board.
6. Power on the sign.

# Section 17: Maintenance

## Digit Replacement Instructions

1. Power off the sign.
2. Disconnect cables from digit and remove old digit.
3. Install new digit and reconnect cables.
4. Power on the sign.
5. Perform a Factory Reset by turning dipswitch 1 to ON.

**Important:** After the factory reset is complete, turn OFF dipswitch 1.

## Built in Power Supply Test

The controller has a built in power supply test. This test will determine if any of the power supplies are outside of normal operating range.

A power supply test should be performed when adding or replacing power supplies.

A power supply test can be started 2 ways.

1. Turn **dipswitch 2** on the master controller (*if there are multiple controllers in the sign*) to the **ON** position and **all other** switches to the **OFF** position. **Dipswitch 2 MUST be turned off after the test completes or a power supply test will occur every time the sign starts.**

-or-

2. Use the Economy remote by entering the installer menu. From the installer menu go to the info menu by pressing **↑** then **4** the sign will display **inFa**. With the sign displaying **inFa** press **↑** then **6** to start a power supply test.

The power supply test can take up to 1 minute depending on the number of power supplies connected.

During the test the sign will change display and brightness levels. When the test is complete the sign will resume its previous display.

## Results

- Fail - The red enable light will blink fast (1/10 second).
- Pass - The red enable light will stay on solid or blink slowly (1 second).
- The number of failed power supplies can also be viewed from the installer menu.

## AC Distribution Board



## Controller board

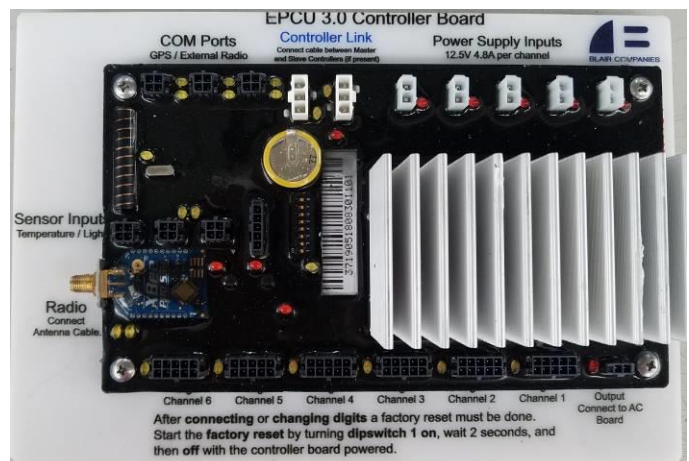

(This page is intentionally left blank)

# EPCU 3.0 WARRANTY CARD

Please complete one form for each



<u>SIGN OWNER</u>	<u>INSTALLER</u>
Company: _____	Company: _____
Contact: _____	Phone: _____
Contact Phone: _____	Address: _____
Store Address: _____	_____
_____	_____
Store Number: _____	
Sign Phone No.: _____ <small>(if applicable)</small>	Blair M#: _____

**INITIAL THE FOLLOWING ITEMS AS COMPLETED. Email or fax completed checklist, invoice, and photos to initiate the warranty. Send to ledsupport at [ledsupport@blairimage.com](mailto:ledsupport@blairimage.com) or fax to 814-949-8293**

- Sign Mounting: **Please check with the owner or general contractor for any changes to the sign placement, height, or orientation before proceeding. Report any discrepancy from the plans.**
- Receipt of all required parts (sign, digits, control system, economy remote, PricePad)
- Receipt of all documents:
  - Installation Instructions
  - User Instructions
  - Sign Specific Wiring Diagram
- Upon completion of the installation,
  - User instructions are left with store manager or owner
  - Install instructions are taken with installer
  - Site was trained on using the economy remote and PricePad.
- Proper installation in accordance with Blair Companies' Installation Guide is required to ensure correct operation. *(Please make note of any problems/resolutions on a separate sheet of paper and submit with this checklist.)*
  - Control System
  - PricePad
  - LED Digits
  - Radio/Antenna – Sign side antenna is mounted on exterior of sign and store side radio is in line of site and away from potential electronic interference.
  - Grounding Rod
  - POS Software & Cables (if applicable)
  - Sign/Panel mounting (if applicable)
- Each line of digits is fully tested and operational.
- After installation, please send photos, invoice, and this form to Blair Companies. Photos must include the following:
  - Photos of interior of sign showing control system (controller board, power supplies, AC distribution board)
  - Photos interior of sign showing digit cable connections to digits
  - Photos of MID or sign faces from both directions with LEDs lit (insure antenna is visible if sign is equipped with PricePad)
  - Photos inside store of store side radio, PricePad, economy remote and store user manual.

**INSTALLER:** By signing, I agree that the sign described at the location above was installed according to the guidelines and that all items on the above checklist were completed. I understand that failure to perform any of the items on the checklist or to install per instructions will result in Installer liability. I also understand that in the event that additional work is required to properly install the sign, all incurred costs will be at my expense.

Installer Name: \_\_\_\_\_ Signature: \_\_\_\_\_  
Date of Install: \_\_\_\_\_ *(if faxed)*

**STORE MANAGER / OWNER:** By signing, I agree that the installation of the sign described at the location above was demonstrated by the installer to be functioning correctly. The installer has reviewed the Installation Checklist with me and I agree that the installer has completed all items in accordance with the checklist.

Owner Name: \_\_\_\_\_ Signature: \_\_\_\_\_  
Date: \_\_\_\_\_ *(if faxed)*

10/5/2023      Revision 3